



MOTION
COMPOSITES



HELIO C2

HELIO A6

RAMQ

USER MANUAL

FOLDING WHEELCHAIRS

motioncomposites.com

MAINTENANCE MANUAL & WARRANTY INFORMATION

Dealer: This manual must be given to the user of the Motion Composites wheelchair before its first use.

User: Before using the Motion Composites wheelchair, read this manual carefully and keep it for future reference.

For more information on products, parts, accessories and services, go to motioncomposites.com.

WHEELCHAIR MOTION COMPOSITES

HELIO C2 & HELIO A6

Thank you for selecting a Motion Composites wheelchair. Please do not hesitate to send us your feedback or questions regarding this product's reliability, safety, usability, as well as any repair/maintenance services offered by an authorized Motion Composites Distributor.

WARNING - READ THIS MANUAL

Do not operate this wheelchair without reading and understanding this User Manual. If you are unable to understand the warnings, cautions and instructions, contact your Motion Composites dealer or customer support at 1 866 650-6555 before attempting to use this wheelchair.

If you ignore this Warning, you may fall, tip over or lose control of the wheelchair and seriously injure yourself or others and damage your wheelchair.

Made in Canada with Canadian and imported parts.

CONTACT INFORMATION

Motion Composites Inc.
160, Armand Majeau Sud
Saint-Roch-de-l'Achigan, Québec
J0K 3H0 Canada

Telephone: 1 866 650-6555
Fax: 1 888 966-6555

info@motioncomposites.com
motioncomposites.com



EUROPEAN AUTHORIZED REPRESENTATIVE

Advena Ltd
Tower Business Centre
2nd Floor, Tower Street
Swatar, BKR 4013, Malta

IMPORTANT INFORMATION

If you have any questions about safety, adjustments, accessories, use, or maintenance, please contact your Authorized Motion Composites Distributor or Dealer.

Please record the following information for future reference:

Date of purchase: _____

Serial Number: _____

Supplier: _____

Address: _____

Telephone: _____

SOPHISTICATED AND AFFORDABLE

We developed our knowledge by creating our HELIO C2 and made it available in an entry-level package of wheelchairs.

By using the latest hydroforming technologies and a high-performance aluminum alloy, we created a complete lineup of Motion Composites ultralight and propulsion-efficient wheelchairs, with an affordable price tag.

ONE OF THE LIGHTEST WHEELCHAIR OF ITS CLASS

We are unrivaled when it comes to lightness, no matter the material used. Thanks to outstanding properties of aluminum 7000 paired with cutting-edge carbon fiber design, a Motion Composites wheelchair with a standard configuration may weigh up to 5 pounds less than the other popular wheelchairs in its category.

WHAT A FOLDING WHEELCHAIR SHOULD BE

Every little detail of the Motion Composites wheelchair was specifically optimized to help you make more movement! Our wheelchair lets you minimize the risk of serious shoulder and joint injuries by alleviating the energy needed to propel. Its light weight and folding mechanism allow you to enjoy greater freedom when traveling and transferring to the car boot.

ADJUSTMENTS WITHOUT THE WEIGHT

The Motion Composites wheelchair is completely adjustable for a perfect fit. You can easily adjust front and rear seat-to-floor heights, seat angle, center of gravity and frame angle.

THE LOWEST SEAT-TO-FLOOR HEIGHT

The innovative frame design of the Motion Composites wheelchair helps achieve up to 13" seat-to-floor height with a 4" caster on a standard frame. The same frame can help reach up to 21½".

GET MORE MILEAGE FOR LESS ENERGY

There are several benefits for an easier-to-propel wheelchair. Thanks to an entirely symmetrical carbon fiber or hydroformed cross brace, oval shaped tubes and oversized pivot axles, our unique Ultrarigid Folding System (UFS) maximizes frame rigidity and energy conservation.



Warning – Wheelchair Selection

Motion Composites manufactures several models of wheelchairs to meet the needs of the end users. However, Motion Composites is not a health care advisor, and we are not aware of the individual condition or needs of the wheelchair user. Therefore, the final selection of a particular model, its adjustments, the type of options and accessories, rest solely with the wheelchair user and the health care professional advisor. Choosing the best chair and setup for your safety depends on the following criteria:

1. Your disability, strength, balance and coordination;
2. The types of hazards you must overcome in daily use (where you live and work and other places you are likely to use your chair);
3. Your needs in terms of options for your safety and comfort (such as anti-tippers, positioning belts or special seating systems). If you ignore this warning, you may endanger your health.



Warning – Tiedown System

Motion Composites recognizes that the safest transit option for a wheelchair user is to transfer in an appropriate seat of the vehicle and to use the motor vehicle restraint system.

If an appropriate transit system must be used, ensure that the wheelchair is equipped with the Motion Composites anchor system. It must also be ensured that the straps, hooks and tiedowns of the Paratransit Vehicle's tiedown system meet the safety standards of the province, state or country where the user is being transported, and installed according to the tiedowns manufacturer's standards.

Motion Composites cannot recommend, and does not recommend, tiedowns or manufacturers of tiedown systems.



Warning – Seating Restraints

It is the obligation of your dealer and health care professionals advising you to determine if you require a seating restraint or positioning system in order to ensure that you can safely operate your wheelchair. A fall from a wheelchair may cause serious injuries.

The information in this document is subject to change without notice. The most recent documents, updates and the latest version of this User Manual are available on motioncomposites.com.

TECHNOLOGIES



HIGH-MODULUS CARBON T700
The lightest and most rigid material available, also renowned for its vibration dampening properties.



ULTRALIGHT ALUMINUM 7005 T6
An aluminum alloy that is renowned for its high strength-to-weight ratio.



RIGID UNIBODY FRAME
A unibody frame is much stronger and helps reduce weight while maximizing propulsion efficiency.



SYMMETRICAL CROSS BRACE 3D
Entirely symmetrical cross brace for reduced torsion and a better distribution of forces.



ULTRARIGID FOLDING SYSTEM
Extremely precise tolerances and oversized pivot axles for best-in-class propulsion efficiency.



FORGED VERTICAL AXLE PLATE
It offers the most precise rear wheel adjustability of the industry. The vertical mounting maximizes rigidity and responsiveness.



EVOLVE CASTER HOUSING
Embedded inside the frame for rock solid durability, the Evolve caster housing offers easy and precise infinite adjustments.



AFS ANTI-FLUTTER SYSTEM
Minimize flutter with a simple twist of a screw.



NEWTON ACCESSORIES
The whole range of Newton accessories are designed to be lighter and offer improved functionalities.

CONTENTS

MOTION COMPOSITES WHEELCHAIR	3	6.4.2	BALANCE POINT	12
WARNING – READ THIS MANUAL	3	6.4.3	WHEELIES	12
CONTACT INFORMATION.....	3	6.4.4	TRANSFERRING	12
1. PRODUCT OVERVIEW.....	7	6.4.5	GETTING DRESSED.....	12
2. BEFORE USE	8	6.4.6	REACHING/LEANING/BENDING.....	12
2.1 GENERAL WARNING.....	8	6.4.7	MOVING BACKWARDS.....	12
2.2 SAFETY INSPECTIONS AND MAINTENANCE.....	8	6.4.8	RAMPS, SLOPES & SIDE HILLS	12
2.3 MOTOR VEHICLE SAFETY.....	8	6.4.9	OBSTACLES	13
2.4 BECOMING ACCUSTOMED TO YOUR NEW WHEELCHAIR.....	8	6.4.10	CURBS AND STEPS	13
2.5 NOTE TO USERS.....	8	6.5	MOVING WITH ASSISTANCE	13
2.6 IMPORTANT WARNING WHEN USING THE STROLLER-HANDLE AND PUSH HANDLES.....	8	6.5.1	CLIMBING A CURB OR SINGLE STEP.....	13
2.7 NOTE TO DEALERS & QUALIFIED TECHNICIANS... 8		6.5.2	DESCENDING A CURB OR SINGLE STEP.....	13
2.8 SYMBOLS.....	8	6.5.3	STAIRS.....	14
3. TUTORIALS.....	9	6.5.4	CLIMBING A FLIGHT OF STAIRS	14
4. TECHNICAL SPECIFICATIONS	9	6.5.5	DESCENDING A FLIGHT OF STAIRS	14
4.1 BACK UPHOLSTERY	9	6.5.6	ESCALATOR	14
4.2 CUSHION	9	7.	RIDING YOUR MOTION COMPOSITES WHEELCHAIR.....	14
4.3 ARMREST PAD.....	9	7.1	FOLDING AND UNFOLDING	14
4.4 LABEL LOCATIONS	10	7.1.1	FOLDING	14
4.5 STRUCTURE.....	10	7.1.2	UNFOLDING.....	14
4.6 DIMENSION	10	7.2	WHEEL LOCKS.....	15
4.7 ADJUSTMENT	10	7.3	FOOTRESTS.....	15
5. SAFETY	11	7.3.1	INSTALLING AND REMOVING	15
5.1 CHECKLIST.....	11	7.3.2	ELEVATING LEGREST	15
5.2 WEIGHT LIMITATION.....	11	7.3.2.1	INSTALLING THE ELEVATING LEGREST	15
5.3 WEIGHT TRAINING AND SPORTING ACTIVITIES.....	11	7.3.2.2	ADJUSTING THE ELEVATING LEGREST	15
5.4 PREVENTION AGAINST TRAPS FOR BODY PARTS	11	7.4	ARMREST	15
5.5 REFLECTING DEVICE.....	11	7.4.1	FLIP BACK "U" ARMRESTS	16
6. RIDING YOUR MOTION COMPOSITES WHEELCHAIR	11	7.4.2	REMOVABLE "T" ARMRESTS	16
6.1 TO REDUCE THE RISK OF ACCIDENTS.....	11	7.4.3	SWING-AWAY "L" ARMRESTS.....	16
6.2 ENVIRONMENTAL CONDITIONS.....	11	7.5	POSITIONING BELTS.....	16
6.3 CAREGIVERS.....	11	7.5.1	AUTO BUCKLE AND AIRCRAFT BUCKLE POSITIONING BELTS	16
6.4 RIDING YOUR WHEELCHAIR	12	7.5.2	VELCRO™ POSITIONING BELT	16
6.4.1 TO REDUCE THE RISK OF A TIP-OVER YOU SHOULD.....	12	7.6	ANTI-TIPPERS.....	16
		7.6.1	ANTI-TIPPERS.....	16
		7.6.2	TIPPING-AID LEVER.....	17
		7.7	REAR WHEELS.....	17
		7.7.1	QUICK-RELEASE AXLES	17
		7.7.2	FIXED AXLES.....	17
		7.7.3	MOTION COMPOSITES ONE ARM DRIVE SYSTEM	17
		7.8	SEAT UPHOLSTERY, RIGID SEAT PAN, CUSHION	17
		7.9	PUSH HANDLES	17
		7.9.1	FOLD-DOWN PUSH HANDLES	18
		7.9.2	HEIGHT ADJUSTABLE PUSH HANDLES	18
		8.	ADJUSTMENTS AND MAINTENANCE OF YOUR MOTION COMPOSITES WHEELCHAIR... 18	
		8.1	SERVICE	18
		8.2	REPLACEMENT PARTS.....	18
		8.3	TOOLS NEEDED	18
		8.4	GENERAL MAINTENANCE	18
		8.4.1	TIRE PRESSURE	18
		8.4.2	PUNCTURE.....	18
		8.4.3	CLEANING YOUR WHEELCHAIR	18
		8.4.4	STORING AND SHIPPING YOUR WHEELCHAIR	18

8.5	BACKREST.....	19	8.12	WHEEL LOCKS.....	26
8.5.1	REMOVING/INSTALLING THE BACKREST	19	8.12.1	REPLACING/ADJUSTING THE WHEEL LOCK.....	26
8.5.2	DEPTH ADJUSTABLE OPTION.....	19	8.13	WHEEL LOCK EXTENSIONS.....	26
8.5.3	ADJUSTING THE BACK ANGLE	19	8.13.1	REPLACING/ADJUSTING THE WHEEL LOCK EXTENSIONS	26
8.5.4	REMOVING/INSTALLING THE POSITIONING BELT.....	19	8.14	ANTI-TIPPERS	26
8.5.5	ADJUSTING THE BACKREST HEIGHT.....	19	8.14.1	ADJUSTING THE HEIGHT OF ANTI-TIPPERS.....	26
8.5.6	ADJUSTING THE 8-DEGREE BACKREST HEIGHT.....	19	8.14.2	TIPPING AID.....	26
8.5.7	REMOVING /INSTALLING STANDARD BACK UPHOLSTERY.....	20	8.15	HEADREST KIT AND HEADREST SUPPORT.....	26
8.5.8	REMOVING/INSTALLING BACK UPHOLSTERY (INTEGRATED PUSH HANDLE)	20	8.15.1	INSTALLING A HEADREST SUPPORT	26
8.5.9	REMOVING/INSTALLING ADJUSTABLE TENSION BACK UPHOLSTERY.....	20	8.15.2	INSTALLING A HEADREST KIT	26
8.6	ARMRESTS	20	8.16	AMPUTEE AXLE PLATE	27
8.6.1	INSTALLING FLIP BACK ARMRESTS.....	20	8.16.1	INSTALLING AN AMPUTEE AXLE PLATE (C2).....	27
8.6.2	ADJUSTING THE HEIGHT OF FLIP BACK AND "T" ARMRESTS	20	8.16.2	AMPUTEE AXLE PLATE (A6).....	27
8.6.3	INSTALLING "T" ARMRESTS AND SIDE GUARDS	20	8.17	CENTER OF GRAVITY EXTENSION PLATE.....	27
8.6.4	INSTALLING THE SIDE GUARD CLAMPS.....	21	8.17.1	CENTER OF GRAVITY FORWARD EXTENSION PLATE (C2)	27
8.6.5	REPLACING ARMREST PAD	21	8.17.2	CENTER OF GRAVITY FORWARD EXTENSION PLATE (A6)	27
8.6.6	INSTALLING SWING-AWAY ARMREST RECEIVER	21	8.18	USING TRANSIT TIEDOWN SYSTEM	27
8.6.7	ADJUSTING SWING-AWAY ARMREST HEIGHT	21	9.	MOTION COMPOSITES LIMITED WARRANTY	28
8.7	FOOTREST HEIGHT	21	10.	PARTICULAR DAMAGES.....	28
8.7.1	ADJUSTING FOOTREST LENGTH	21	10.1	PARTS REPAIRED BY THE SERVICE CENTER	28
8.7.2	ADJUSTING FOOTREST LENGTH (SWING AWAY TYPE).....	21	10.2	SPECIAL CONDITIONS FOR RETURNING THE WHEELCHAIR TO THE MANUFACTURER	28
8.7.3	ADJUSTING FOOTREST LENGTH (SINGLE FOOT PLATE TYPE).....	21	10.3	REPAIR PROCEDURE	28
8.7.4	ADJUSTING FOOTPLATE ANGLE.....	22	10.4	TOOLS	29
8.7.5	INSTALLING AND ADJUSTING THE LIMB SUPPORT.....	22	11.	PERIODIC CHECKLIST	29
8.7.6	CLEANING THE LIMB SUPPORT.....	22	12.	DECLARATION OF CONF ORMITY	29
8.8	SEAT	22	ISO 7176-19 OCCUPIED TRANSIT ANCHOR KITS ...30		
8.8.1	REPLACING SEAT UPHOLSTERY.....	22	RAMQ WARRANTY CERTIFICATE.....38		
8.8.2	REPLACING THE RIGID SEAT	22			
8.9	SEAT-TO-FLOOR HEIGHT	22			
8.9.1	CHANGING THE FRONT SEAT-TO-FLOOR HEIGHT.....	22			
8.9.2	CHANGING REAR SEAT-TO-FLOOR HEIGHT.....	22			
8.9.3	CHANGING FRONT & REAR SEAT-TO-FLOOR HEIGHT.....	23			
8.10	CASTERS, FORKS AND FORK STEM ASSEMBLIES.....	23			
8.10.1	REMOVING/INSTALLING/REPOSITIONING CASTERS	23			
8.10.2	REMOVING/INSTALLING THE CASTER HOUSING (C2).....	23			
8.10.3	REMOVING/INSTALLING THE CASTER HOUSING (A6).....	23			
8.10.4	CHECKING/ADJUSTING THE CASTER HOUSING ANGLE (C2).....	23			
8.10.5	CHECKING/ADJUSTING THE CASTER HOUSING ANGLE (A6).....	24			
8.10.6	REMOVING/INSTALLING FORK STEM ASSEMBLIES	24			
8.11	REAR WHEELS.....	24			
8.11.1	ADJUSTING QUICK-RELEASE AXLES	24			
8.11.2	REPLACING/ADJUSTING HANDRIMS.....	24			
8.11.3	ADJUSTING THE REAR AXLE HEIGHT (C2).....	24			
8.11.4	ADJUSTING THE REAR AXLE HEIGHT (A6).....	25			
8.11.5	ADJUSTING REAR WHEEL SPACING	25			
8.11.6	CHANGING REAR CAMBER.....	25			
8.11.7	ADJUSTING THE CENTER OF GRAVITY	25			

1. PRODUCT OVERVIEW

PARTS LIST

- 1 Push handle
- 2 Back cane
- 3 Arm pad
- 4 Rear wheel and handrim
- 5 Armrest
- 6 Footrest
- 7 Footplate
- 8 Caster
- 9 Fork
- 10 Caster Housing
- 11 Wheel lock
- 12 Cross brace
- 13 Rear wheel mounting plate
- 14 Seat rail
- 15 Side guard
- 16 Anti-tipper

**May be different from the images shown, depending on the selected configuration.*

HELIO C2 & HELIO A6

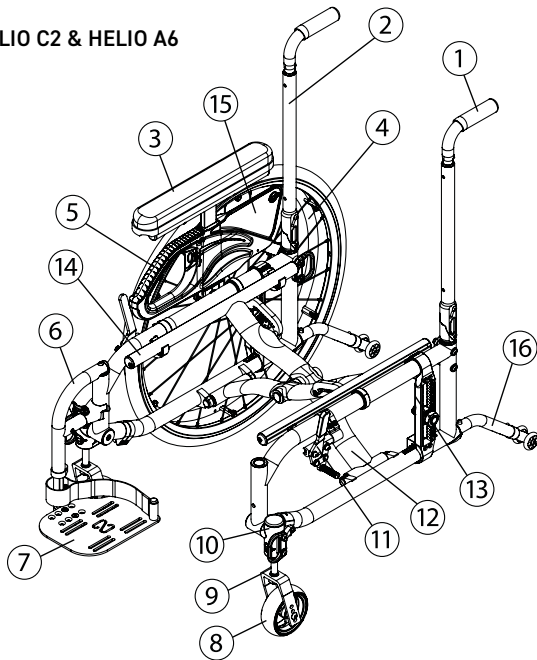

HELIO C2



HELIO A6

2. BEFORE USE

2.1 GENERAL WARNING



WARNING

Your Motion Composites wheelchair has been designed using cutting edge technologies on aluminum or carbon fiber materials and comes with special warnings. **DO NOT MODIFY THE FRAME BY ANY MEANS. THE FRAME MAY BE SEVERELY DAMAGED IN CASE OF DRILLING AND GRINDING, THUS VOIDING THE WARRANTY.** Only use Motion Composites approved and designed clamps and accessories on your Motion Composites wheelchair.

- DO NOT use while under the influence of alcohol or medication or drugs. This may impair your ability to operate the wheelchair. Kindly refer to your physician regarding the effects of your medication.
- The wheelchair is not intended for visually impaired people.
- The user needs to be mentally and physically suitable to drive the wheelchair.



CAUTION

Extreme temperatures

Risk of hypothermia or burns on wheelchair parts. Do not expose the product to any extreme temperatures such as direct sunlight, sauna, extreme cold in order to prevent injuries by contact with some parts of the wheelchair.

Environmental Conditions

Do not expose the wheelchair to temperatures below -20°C or above 40°C.

2.2 SAFETY INSPECTIONS AND MAINTENANCE

It is important to keep your wheelchair in proper working condition.

1. ALWAYS inspect and maintain your Motion Composites wheelchair strictly in accordance with the instructions and charts in chapter 8.4 *General Maintenance* and chapter 11. *Periodic Checklist*.
2. If you detect a problem in the course of your inspections or maintenance, ALWAYS have the wheelchair serviced or repaired to correct the problem before using it.
3. ALWAYS have your wheelchair completely inspected and serviced by an authorized Motion Composites certified technician at least once a year.
4. ALWAYS perform your safety inspections and any maintenance or necessary adjustments while the chair is unoccupied (unless this manual expressly states otherwise).

Failure to inspect or maintain your wheelchair as outlined in this Manual could cause you to fall, tip over or lose control of your wheelchair and seriously get injured, seriously injure others or damage the wheelchair.

2.3 MOTOR VEHICLE SAFETY



WARNING

Identify whether your wheelchair was manufactured with the Paratransit Option installed.

If your chair is NOT equipped with the appropriate Paratransit Option: The Motion Composites wheelchair is NOT designed to be used for seating in a motor vehicle and the wheelchair does NOT meet Federal Highway standards for motor vehicle seating.

NEVER sit in your chair while in any type of moving vehicle (bus, automobile, van, truck, boat, train, etc.). In a crash or sudden stop, you may be ejected from the wheelchair. In a crash or sudden stop, a wheelchair positioning belt will NOT prevent injuries.

ALWAYS transfer to an approved vehicle seat before the vehicle begins moving.

ALWAYS secure yourself in the approved vehicle seat using (the) proper seating restraints (in a motor vehicle, a lap/shoulder belt; in a plane, a lap belt, etc.).

NEVER transport your wheelchair in the front seat of a vehicle.

Movements of the vehicle may cause the wheelchair to shift and interfere with the driver's ability to control the vehicle.

When transporting your wheelchair in a moving vehicle, ALWAYS secure your wheelchair so that it cannot roll or shift. In most cases, stowing it in the car boot is the safest alternative.

NEVER use any wheelchair that has been involved in a motor vehicle crash. A wheelchair that has been involved in a motor vehicle crash may be damaged in ways that are not readily apparent and which could cause the wheelchair to fail in use.

If you ignore these warnings, you may fall, tip over or lose control of the wheelchair and seriously injure yourself or others and damage the wheelchair.



WARNING

The Motion Composites wheelchair is available with an ISO 7176-19 anchor system for appropriate occupied transit. This option is only offered as a factory-installed option. Kindly refer to the anchorage manual ISO 7176-19 to operate the transit option safely.

2.4 BECOMING ACCUSTOMED TO YOUR NEW WHEELCHAIR



WARNING

Each wheelchair is a unique piece of medical equipment. Whether you are a new wheelchair user or have years of experience, you MUST take the time to acclimate to the wheelchair before you begin riding. Start slowly and take the time to learn the handling, maneuvering and ride characteristics of this wheelchair.

2.5 NOTE TO USERS

The Motion Composites wheelchair is a manually operated device intended to be used as a means of mobility for a person restricted to a sitting position. It is not indicated for the pediatric population.

Carefully read the instructions in this manual before using or servicing your Motion Composites wheelchair. If you have any questions or difficulties understanding the following instructions, kindly refer to your qualified technician. You may also wish to contact a Motion Composites technician by phone or email (see contact information at the beginning of this Manual).

2.6 IMPORTANT WARNING WHEN USING THE STROLLER-HANDLE AND PUSH HANDLES



WARNING

The stroller-handle is not designed to lift or pull the weight of user in the wheelchair. It is designed to push and guide the wheelchair user. Weight limit: 120 kg (265 lb).

Lifting or pulling the weight of the user in the wheelchair could trigger the breakage of the push-handle and cause serious injuries.

2.7 NOTE TO DEALERS & QUALIFIED TECHNICIANS

Read this manual before servicing, repairing, operating or adjusting the Motion Composites wheelchair. If you have any questions or difficulties understanding the following instructions, kindly send us a mail or contact a Motion Composites technician (see contact information at the beginning of this manual).

2.8 SYMBOLS

The following symbols are used throughout this manual. Please familiarize yourself with their meaning.



The warning sign indicates important information to prevent injuries and property damage.



Useful information for the user.

Other warnings and important information:



Initial setup of your Motion Composites wheelchair must be done by a qualified technician.



Regular servicing of your Motion Composites wheelchair will extend the life of the wheelchair. Take your wheelchair to a qualified technician every year for inspection and servicing.



Do not tighten the screws using an air or electric tool; final tightening should be done manually using appropriate torque and threadlocker

The latest version of this manual can be found on our website at motioncomposites.com

3. TUTORIALS

Find the latest tutorials or information and contact our team at motioncomposites.com

4. TECHNICAL SPECIFICATIONS

4.1 BACK UPHOLSTERY

All back upholstery are made with waterproof material that can be cleaned.

Seams are not waterproof.

The adjustable tension back upholstery is made up of waterproof material.

Active-Mesh or Syntech Suede, found on nylon slip-on or semiten-sion adjustable back upholstery, can absorb moisture.

- Padding: foam
- Thickness: 10 mm
- Compression hardness: 0.231 - 0.258 kPa
- Foam volume weight: 32.0 - 33.6 kg / m³
- Cover material: polyester and nylon antimicrobial and antifungal, Cal-117 fire resistant



4.2 CUSHION

All cushions are made of waterproof material that can be cleaned.

Seams are not waterproof.

- Padding: foam
- Thickness: 2 in. or 3 in. / 51 or 76 mm
- Compression hardness: 0.245 - 0.289 kPa
- Foam volume weight: 43.2 - 46.5 kg / m³
- Cover Material: Polyurethane Antimicrobial and Antifungal, Cal-117 fire Resistant

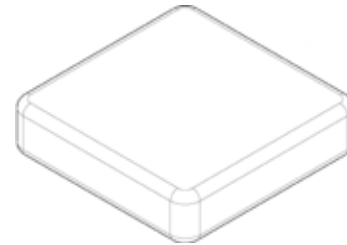
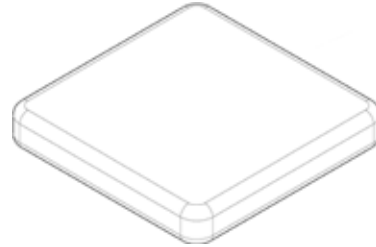

4.3 ARMREST PAD

The armrest is made up of waterproof material that can be cleaned.

- Padding: foam
- Thickness: 26 mm
- Compression hardness: 0.495 - 0.510 kPa
- Foam density: 69.2 - 71.5 kg / m³
- Cover material: vinyl

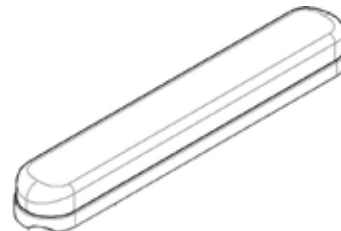

4.4 LABEL LOCATIONS

1. Location on the frame
2. Manufacturer name
3. Manufacturer address
4. Category
5. Product Name
6. Manufacturing year and month
7. Serial Number
8. Weight Limit
9. Read the manual before use
10. Anit-tippers label
11. ISO 7176-19 Standard

Do not remove or alter any labels on the wheelchair. If label is damaged or becomes illegible, replace it with a new one.

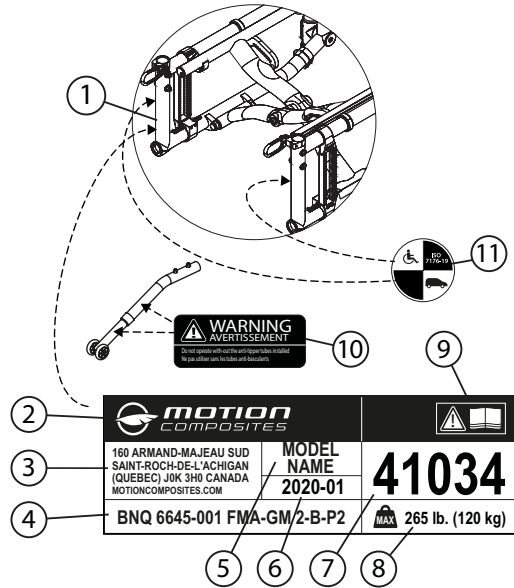

4.5 STRUCTURE

MODEL	FRAME	MATERIAL	TRANSPORT WEIGHT*	LIGHTEST CONFIGURATION**	CAPACITY
HELIO C2	• Molded • Folding	T700 High-Modulus carbon fiber	4.3 kg (9.5 lb)	8.8 kg (19.3 kg)	120 kg (265 lb)
HELIO A6	• Hydroformed • Folding	• 6061 Aluminum	6.0 kg (13.1 lb)	10.4 kg (22.9 lb)	120 kg (265 lb)

* Without rear wheels, cushion, armrests, and wheel locks.

** With Newton wheel locks, 80°footrests, composites footplate, Newton Gravity rear wheels, cushion, anti-tippers and armrests/clothing guards not included.

4.6 DIMENSION

MODEL	WIDTH	DEPTH	FRONT SEAT-TO-FLOOR HEIGHT	REAR SEAT-TO-FLOORHEIGHT
HELIO C2	30.5 cm to 50.8 cm 12 in to 20 in	30.5 cm to 50.8 cm 12 in to 20 in	33 cm to 54.6 cm 13 in to 21½ in	30.5 cm to 51.4 cm 12½ in to 20½ in
HELIO A6	35.6 cm to 50.8 cm 14 in to 20 in	35.6 cm to 50.8 cm 14 in to 20 in	30.5 cm to 52 cm 12 in to 20½ in	30.5 cm to 51.4 cm 12 in to 20½ in

4.7 ADJUSTMENT

MODEL	BACK	BACK HEIGHT	ADJUSTABLE ANGLE	FOOTREST	TILT	CENTER OF GRAVITY
HELIO C2	• Adjustable tension, flexible or rigid	22.9 cm to 61 cm 9 in to 24 in	85° to 110°	Swing-in /Swing-out	0°, 3°, 6°	2.5 cm to 11.4 cm 1 in. to 4½ in. + amputee axle plate
HELIO A6	• Adjustable tension, flexible or rigid	22.9 cm to 61 cm 9 in to 24 in	85° to 110°	Swing-in /Swing-out	0°, 3°, 6°	1.9 cm to 9.5 cm 0.75 in. to 3¾ in. + amputee axle plate

5. SAFETY

5.1 CHECKLIST

See section 11. *Periodic Checklist.*

5.2 WEIGHT LIMITATION

- The Motion Composites wheelchair has a weight limit of 265 lb (120 kg). The specified weight capacity includes both the rider, as well as any luggage transported or attached to the chair (for example, a backpack). Kindly make sure the total weight is below the above specified capacity. For example, if the user transports a bag of 5 kg (10 lb), its weight limit will be 115 kg (255 lb) on a standard wheelchair with a limit of 120 kg (265 lb).
- Motion Composites is not responsible for any damages or injuries caused by the misuse of this wheelchair.

5.3 WEIGHT TRAINING AND SPORTING ACTIVITIES

- Our wheelchairs were not designed or tested as a weight training or stretching apparatus, or for stretching exercises. The warranty shall be void if the wheelchair has been used for any weight training or stretching purposes.
- This wheelchair is not intended to be used during sporting activities.



CAUTION

Should you make any adjustments, repairs or do any servicing, ensure that all fasteners are tightly secured before use.



WARNING

Exceeding the specified weight limit may damage the wheelchair and/or cause serious injuries.



WARNING

This wheelchair was designed to be tailored to the dimensions of its owner. As such it should only be used by its owner unless a qualified specialist, approved by Motion Composites, has readjusted it.

5.4 PREVENTION AGAINST TRAPS FOR BODY PARTS

Particular attention should be paid to body parts that are close to moving components of the wheelchair such as the rear wheels and casters. Hands should be outside the rear wheels, close to the handrims when riding. Wheel locking mechanisms should only be applied when the wheelchair is completely stopped.

5.5 REFLECTING DEVICE

Reflecting systems are available as option and ensure more visibility for user safety.

6. RIDING YOUR MOTION COMPOSITES WHEELCHAIR



CAUTION

Any adjustment to the wheelchair (seat height, depth, backrest angle, tilt, wheel size and position, footrest position) could affect the center of gravity. The adjustments should be performed by a professional and the user should be informed that the stability could be affected by these adjustments.



WARNING

DO NOT tilt the wheelchair or perform a wheelie without assistance.



WARNINGS

- DO NOT stand on the wheelchair or a part of its frame.
- DO NOT sit or transfer into the wheelchair unless it is fully open and the seat rails are fully seated into the receivers.
- DO NOT use the footplate as a platform when getting in or out of the wheelchair or to reach for an object.

6.1 TO REDUCE THE RISK OF ACCIDENTS

- We recommend that you review safe wheelchair use with your therapist prior to using this equipment safely.
- Take the time to read the instructions in this manual to ensure that you feel comfortable using the wheelchair without assistance.
- Always be aware of hazards in the environment.
- Unless you are a skilled rider of this wheelchair and that you are sure you are not at risk to tip over, always use anti-tippers. Because anti-tippers are an option in some markets on this wheelchair, Motion Composites strongly recommends ordering them as they are an important safeguard for the wheelchair user.
 - Always use anti-tippers if you are not a skilled rider.
 - Always use anti-tippers each time you modify or adjust your wheelchair. Any change may make it easier to tip backward.
 - Use anti-tippers until you adapt to the change, and are sure of not being at risk to tip over.

6.2 ENVIRONMENTAL CONDITIONS

- The Motion Composites wheelchair was designed to be used on hard and plane surfaces like asphalt, concrete, and on indoor surfaces such as hard flooring or carpeting.
- DO NOT operate on roads, streets or highways.
- Beware that the maneuverability of the wheelchair is significantly affected by outside conditions such as sand, mud, rain, snow and rough surfaces. If used in such conditions, it is recommended to frequently have it serviced.
- Be careful when using your wheelchair on wet or slippery surfaces. Exposure to water or excessive moisture can be damaging and may even cause the wheelchair to corrode over the long-term. Some accessories of this wheelchair may be affected by corrosion.
- Do not leave your wheelchair in excessive humid environments, such as a humid bathroom especially when taking the shower or under the shower.

6.3 CAREGIVERS

- Never use removable parts (e.g., armrests, footrests) to push or lift the wheelchair when it is occupied, since they could be detached and cause injuries and/or damage the chair.
- Ensure that the wheelchair is equipped with push handles and that its grips are securely in place.
- Turn anti-tipping devices upwards or remove them to avoid tripping. Remember to return them to their correct position as soon as you stop riding the wheelchair.
- Should you need to leave the wheelchair user unattended, engage the wheel locks and place the anti-tipping devices back in the downward position.
- Ask an experienced caregiver to explain user safe assistance methods to you.
- Ensure ongoing communication between you and the wheelchair user as to avoid any kind of confusion or surprises related to mutual expectations.
- Maintain proper posture to tilt or lift the wheelchair; keep your back straight and bend at the knees.
- Instruct the wheelchair user to lean his/her back when you are tilting the wheelchair.

6.4 RIDING YOUR WHEELCHAIR

6.4.1 TO REDUCE THE RISK OF A TIP-OVER, YOU SHOULD:

- 1 CONSULT your doctor, nurse or therapist to find out what axle and caster position and other chair configuration options are best for you.
- 2 CONSULT your authorized Motion Composites dealer BEFORE modifying or adjusting your wheelchair. Often, an adjustment you wish to make can be offset by the one you have not considered. For example, you may want to adjust the back angle rearward, which will increase the likelihood of a rear tip-over. You might not think you could counteract this tendency by moving the rear wheels backward. Your authorized Motion Composites dealer will be able to give you expert, personalized advice in such matters.
- 3 ALWAYS have someone assist you until you learn your chair's balance points and are completely comfortable in your ability to operate your chair under all conditions so as to avoid tip-overs.
- 4 ALWAYS use both anti-tippers.

If you ignore these Warnings, you may fall, tip over or lose control of the wheelchair and seriously injure yourself or others and damage the wheelchair.

6.4.2 BALANCE POINT

- It is important to begin by learning all of the specific characteristics of your wheelchair in the company of your therapist.
- Any additional weight will modify the balance point of your wheelchair.
- Be aware of new riding characteristics following any modification of your wheelchair.
- Your body position, posture or weight distribution will shift the center of gravity of your wheelchair.
- The center of gravity is affected by the angle of the wheelchair on a ramp or slope: front to back or by the side.
- Have someone help you learn the various riding techniques. Always use the anti-tippers if you are not experienced in riding the wheelchair with its current adjustments.

6.4.3 WHEELIES

- Raising the wheelchair involves lifting the front wheels off the ground and maintaining balance on the rear wheels.

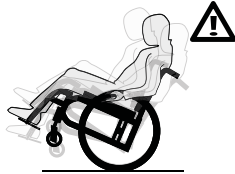

- DO NOT attempt to perform a wheelie in your wheelchair because of the dangerous nature of this kind of maneuver. Motion Composites recognizes that some wheelchair users will ignore this warning. If you decide to ignore this warning, you should follow these steps to help learn to do a wheelie as safely as possible.
- NEVER attempt to learn to do a wheelie without first consulting your therapist. NEVER attempt to learn to do a wheelie without an assistant that can catch you if it happens that you start to fall. NEVER attempt to learn to do a wheelie unless you are a skilled rider on this chair.
- Motion Composites always recommend using both anti-tippers at all time, unless they need to be removed to go up or down a curb or steps.

WARNING

Anti-tippers should be reinstalled once the curb/step is cleared.

6.4.4 TRANSFERRING

- Rotate the casters forward to enhance the stability of the chair.
- Place the wheelchair as close to your transfer location as possible.
- Engage wheel locks.
- Position yourself as far back as possible when transferring

weight to reduce the risk of tipping forward. If you have good upper body strength, balance and agility, you may be able to perform transfers independently.

- Avoid leaning on footrests. Rotate them on the side or remove them if possible. If possible, use a transfer board.

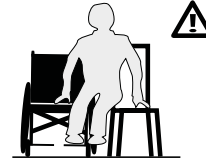

WARNINGS

Always ask a therapist to teach you safe transfer methods. For security reasons, the user should always shorten the transfer distance to the minimum. DO NOT sit or transfer into the wheelchair unless it is fully open and the seat frame rails are fully seated into the receivers. DO NOT use the footrests as a platform when getting in or out of the wheelchair or to reach for an object.

6.4.5 GETTING DRESSED

- When dressing or undressing on the wheelchair, rotate the casters forward, position anti-tippers in the lower position and lock the wheels.
- If your wheelchair is not equipped with anti-tippers, back it against a wall and lock the rear wheels.

6.4.6 REACHING/LEANING/BENDING

CAUTION

The center of gravity may shift when you are putting on clothes and that you bend or stretch on the wheelchair.

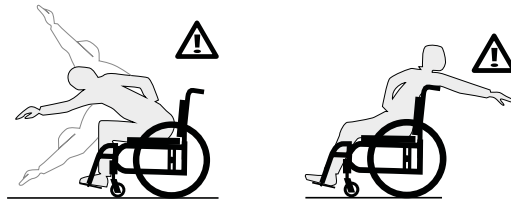

- If possible, use a tool to reach for an object to increase your reach or ask for assistance.
- Move the wheelchair as close to the required object as possible.
- Turn front wheels forward.
- At all times, make sure you are seated fully in the seat to ensure your safety.
- Never lean backwards unless the wheelchair is equipped with anti-tippers.
- Never try to reach for an object behind the seat. Reach only for objects within reach without moving on the seat.
- DO NOT lock the rear wheels if you are bending backwards.
- Avoid leaning on footrests.

6.4.7 MOVING BACKWARDS

- Make sure both anti-tippers are well fixed and turned downwards.
- Move slowly as the wheelchair is designed to provide more stability when moving forward. Look around as often as possible to avoid obstacles in your path.

6.4.8 RAMPS, SLOPES & SIDE HILLS

RAMPS OF 10 FEET (3 METERS) OR LESS IN LENGTH

- If you need to use a short ramp of 10 feet (3 meters) or less, the angle of the slope should not exceed 10 degrees, which corresponds to a slope of 17.63%, a rise of 1.74 feet (0.53 meters) over a distance of 10 feet (3 meters).

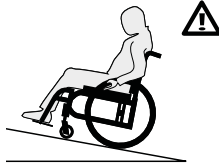

- Make sure to be assisted by a caregiver who is physically able to retain the wheelchair and its occupant.
- The wheelchair must always point facing up the slope.
- The caregiver should always remain in the bottom of the slope to retain the wheelchair.
- Always lock the anti-tippers in the safe position.
- Follow the same words of caution for hills or slide hills of 10% or less.
- Do not use your wheelchair on a ramp below 3 meters in length if the slope angle is greater than 10 degrees (17.63%).

SLOPES AND SLIDE HILLS OF 10 FEET (3 METERS) OR MORE IN LENGTH

- If you must go through a slope or a vertical rise of 10 feet (3 meters) or more, the angle of the slope should not exceed 5.7 degrees, which corresponds to a 10% slope, that is a rise of 3.28 feet (1.00 meter) for a distance of 30 feet (10 meters).

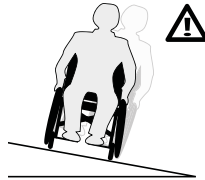

- Make sure to be assisted by a caregiver if you have trouble on the slope or if the slope is between 5.7 and 10 degrees.
- Move your weight in the slope direction to adjust your center of gravity.
- Stay in the center of sidewalks and ensure that there is enough space for the wheels.
- Try to move straight up or down the slope.
- Avoid turning on a downhill slope.
- Avoid stopping on slopes and never use the wheel locks to slow yourself on a downhill slope.
- Keep pressure on the handrims to control your speed.
- Do not ride on wet or slippery surfaces. Be cautious for changes in terrain height or stairs at the end of a slope (casters may lock from simply hitting a small bump upon descending a slope).
- Do not use your wheelchair alone on a slope or slide hills above 3 meters in length if the slope angle is greater than 5.7 degrees (10%).

6.4.9 OBSTACLES

- Always look for obstacles or road hazards (potholes, broken surfaces, etc.)
- Clear your own home/working environment of any obstacles. Never use objects (furniture, ramps, and doorknobs) to push yourself out of the wheelchair.
- Bend your upper body slightly forward as you move up an obstacle and bend slightly backward as you move down it.
- Keep both hands on the handrims while passing over the obstacle.

6.4.10 CURBS AND STEPS

- Curbs and steps are extremely dangerous obstacles.
- NEVER attempt to go up or down a single curb or step without an assistant unless you are a very skilled rider of your chair. You need to have previously learned to safely do a wheelie in your chair and to be sure you have the strength and balance to control your chair during any such maneuver.
- ALWAYS unlock and rotate anti-tippers up and out of the way so they do not prevent you from executing this maneuver.
- NEVER attempt to climb or descend a curb or step more than 4" (10 cm) high.

- ALWAYS go straight up or down a curb or step. NEVER climb or descend at an angle.
- ALWAYS be aware that the impact of descending a curb or step can damage your chair or cause components to become loose.
- If you perform such maneuvers, inspect your chair more frequently.
- ALWAYS rotate and lock the anti-tippers back to ride safely.

6.5 MOVING WITH ASSISTANCE

Caregivers should read the 6.3 Caregivers section of this manual.

6.5.1 CLIMBING A CURB OR SINGLE STEP



WARNINGS

1. NEVER attempt to negotiate a curb or single step without assistance.

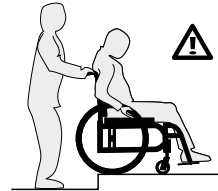

2. Instruct your assistant to stand at the rear of your wheelchair, with the front of the wheelchair facing the obstacle.
3. NEVER attempt to negotiate any such obstacle backward.
4. Instruct your assistant to tilt the chair up on the rear wheels so that the casters clear the curb or step.
5. Instruct your assistant to slowly move the chair forward and to gently lower the casters to the upper level as soon as you are sure that they are beyond the edge of the curb or step.
6. Instruct your assistant to continue rolling the chair forward until the rear wheels are on the curb or step.
7. Instruct your assistant to lift and roll the rear wheels up to the upper level.
8. Instruct your assistant to never attempt to completely lift the wheelchair with the push handles

6.5.2 DESCENDING A CURB OR SINGLE STEP



WARNINGS

1. NEVER attempt to negotiate a curb or single step without assistance.
2. When you are still several feet or a couple of meters from the edge of the curb or step, instruct your assistant to stand at the rear of your wheelchair and turn it around to face away from the curb.

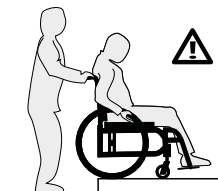

3. NEVER attempt to negotiate any curb or similar obstacle facing forward.
4. Instruct the assistant to carefully step backwards, pulling the wheelchair backwards, until he or she is off the curb or single stair and standing on the lower level. The assistant should watch his or her step over his or her shoulder when going backwards this way.
5. Instruct the assistant to carefully pull the wheelchair backward until the rear wheels reach the edge of the curb or step, then allow the rear wheels to slowly roll down to the lower level.
6. Instruct the assistant that, when the rear wheels are safely on the lower level, he or she may then tilt the chair backward to the balance point of the rear wheels, thereby raising the rear wheels off the upper level.
7. Instruct the assistant to slowly roll the wheelchair backward on the rear wheels, taking small steps until the

casters have cleared the step or curb and, when clear, to gently lower the casters down the obstacle.

8. Instruct your assistant to never attempt to completely lift the wheelchair with the push handles.

6.5.3 STAIRS

- Use an elevator wherever possible.
 - Ask for help from two people to move the wheelchair up or down stairs.
- The caregivers should read the 6.3 *Caregivers* section of this manual so as to help you safely.
- Fasten your positioning belt when being lifted in the wheelchair.
 - Assistants should always grab the frame of the wheelchair to lift you. NEVER grab the push handles, backcanes, wheels, footrests or any moving parts to lift the wheelchair

6.5.4 CLIMBING A FLIGHT OF STAIRS

WARNING

Do not climb a flight of stairs with the user in the wheelchair.

Motion Composites recognizes that wheelchair users may, on occasion, have no other choice and will need to be moved up or down a flight of stairs or will need to be lifted. Only when there is no other alternative, caregivers and wheelchair users should follow these steps to climb a flight of stairs.

1. NEVER attempt to negotiate more than one step unless you have 2 (two) able adult assistants.
2. ALWAYS position the wheelchair and user facing away from the stairs, with one assistant at the rear (facing away from the stairs) and one at the front of the wheelchair (facing the user).
3. The assistant at the rear of the wheelchair is in control and know how to climb a flight of stairs. He or she must tilt the wheelchair back to find its balance point on the rear wheels.
4. NEVER attempt to lift a wheelchair using any removable (detachable) parts, including upholstery, removable push handles or push handle grips.
5. ALWAYS hold the wheelchair from a solid part of the frame.
6. The second assistant at the front must firmly grip the frame (NOT the footrests) with both hands and lift the wheelchair up and over one stair at a time.
7. Each assistant then carefully moves wheelchair to the next stair.
8. Repeat steps 1 through 6 for each stair, until you reach the top of the flight of stairs.
9. When you reach the top of the flight of stairs, the assistants should roll the wheelchair backward on the two rear wheels until the wheels have cleared the last step. At this point, assistants can gently lower the casters on the floor.
10. Assistants should always grab the frame of the wheelchair to lift you. NEVER grab the push handles, back canes, wheels, footrests or any moving parts to lift the wheelchair

6.5.5 DESCENDING A FLIGHT OF STAIRS

WARNING

DO NOT DESCEND the flight of stairs with the user in the wheelchair.

Motion Composites recognizes that wheelchair users may, on occasion, have no other choice and will need to be moved up or down a flight of stairs. Only when there is no other alternative, caregivers and wheelchair users should follow these steps to descend a flight of stairs.

1. NEVER attempt to negotiate more than one step unless you have 2 (two) able adult assistants.
2. Always position the wheelchair and user facing the stairs, with one assistant at the rear (facing away from the stairs) and one at the front of the wheelchair (facing the user).
3. The assistant at the front of the wheelchair is in control and know how to descend a flight of stairs. He or she must tilt the wheelchair back to find its balance point on the rear wheels.
4. NEVER attempt to lift a wheelchair using any removable (detachable) parts, including upholstery, removable push handles or push handle grips.
5. ALWAYS hold the wheelchair from a solid part of the frame.

6. The second assistant at the front must firmly grip the frame (not the footrests) with both hands and control as the user goes down the wheelchair over one stair at a time.
7. Each assistant then carefully moves the wheelchair to the next stair.
8. Repeat steps 1 through 6 for each stair, until you reach down of the flight of stairs.
9. When you reach down of the flight of stairs, the assistants should move the wheelchair forwards until the wheels have cleared the last step. At this point the assistants may gently lower the casters and rear wheels on the floor.
10. Assistants should always grab the frame of the wheelchair to lift you. NEVER grab the push handles, backcanes, wheels, footrests or any moving parts to lift the wheelchair

If you ignore these Warnings, you may fall, tip over or lose control of the wheelchair and seriously injure yourself or others and damage the wheelchair.

6.5.6 ESCALATOR

Under no circumstances should this wheelchair be used on an escalator, not even with the help of an assistant. This could cause severe injuries.

7. RIDING YOUR MOTION COMPOSITES WHEELCHAIR

7.1 FOLDING AND UNFOLDING

7.1.1 FOLDING

- Rotate footrests forward until they lock in position.
- Flip up the footplates.
- Remove the seat cushion and the rigid seat pan, if applicable.
- Grasp the central handle on the seat and pull upwards.
- Finish closing the wheelchair by pulling the wheels together.

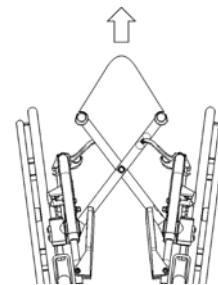

7.1.2 UNFOLDING

CAUTION

When unfolding the wheelchair, be careful not to put your fingers between the pivot links, or under the seat rails.

Avoid putting your fingers around seat rails.

Make sure you always keep your hands on the seat upholstery at all times when pushing the seat rails into their support.

Make sure the wheelchair is fully open before transferring or sitting.

- Tilt the wheelchair towards you; make sure the opposite wheels are off the ground.
- Push the edge of the seat upholstery as close as possible to you until it is as in the manual.
- Press downwards on both seat rails in order to engage the lock mechanism of the wheelchair. Sometimes, it is necessary to press on the back of the seat to make sure that they are correctly positioned in the seat rail supports. You will feel a click between frame components.
- If the chair has a rigid seat pan option, reinstall it.

7.2 WHEEL LOCKS



WARNINGS

Never use wheel locks to slow or stop wheelchair movement. WHEEL LOCKS ARE NOT BRAKES.

Make sure the surface is not slippery as the wheelchair could move even though the wheel locks are engaged.

Make sure the stem locks embed at least 3 mm when they are engaged. The tire must be inflated properly.

Make sure the wheelchair is stable and fully locked before wheel locks are engaged.

- To engage the locks, push the wheel lock handle forward (for push-to-lock type) or pull wheel lock backward (for pull-to-lock type) until the lock is fully engaged and that the wheelchair is stable.
- To release the locks, pull the wheel lock handle backward (for push-to-lock type) or push wheel lock handle forward (for pull-to-lock type) until the lock is fully released.

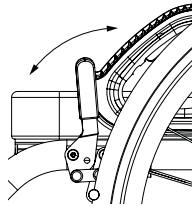

INFORMATION

Note that for the one-sided lock, the engagement or disengagement of the wheel lock is done on one side only.

7.3 FOOTRESTS

7.3.1 INSTALLING AND REMOVING

INSTALLATION

- Insert the front rigging pivot into the wheelchair's mounting tube.
- Then, rotate the front rigging outward the wheelchair and rotate it forward until the mechanism locks into place.
- Repeat this procedure for the other side.

REMOVING

- Push the release locking lever (1) (Fig. a) inward or outward and maintain that position so that the front riggings can rotate freely.
- Rotate front riggings outwards or inwards to disengage the locking mechanism.
- Lift the front riggings up (Fig. b) so as to disconnect it from the footplate.
- Repeat this procedure for the other side.



Fig. a



Fig. b

OPENING AND CLOSING THE FOOTREST WITH FULL-WIDTH FLIP-UP FOOTPLATE

- The HELIO C2 may be supplied with an optional flip-up (Fig. c).
- The single flip-up model can be opened and closed the following way:
- Rotate the ring (1) to unlock and open the locking mechanism.
- Lift (2) the footplate to open.

- When closing make sure to secure the shaft head in the locking mechanism.
- Make sure the footplate is secure once closed.

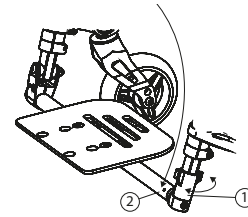

Fig. c

- When transferring, avoid putting weight on the footrest and be careful not to stand behind the footplate.
- Never use footrests to lift the wheelchair.
- Only use non-detachable parts to lift the wheelchair.

7.3.2 ELEVATING LEGREST

7.3.2.1 INSTALLING THE ELEVATING LEGREST

- Remove the actual footrest, see section 7.3.1.
- Install the elevating legrest the same way to install a footplate, see section 7.3.1.

7.3.2.2 ADJUSTING THE ELEVATING LEGREST

- To change the legrest length, pull on the lever (1) to open the clamp.
- Change the length and push on the lever (1) to close the clamp.
- To change the legrest angle, set the desired angle while pushing on the red button (2).

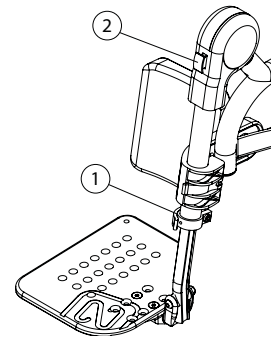

7.4 ARMREST



WARNING

Ensure that armrests are securely locked into armrest sockets before using it.

- Never lift the wheelchair by holding the armrests.
- Only use non-detachable parts to lift the wheelchair.

7.4.1 FLIP BACK "U" ARMRESTS

TO LIFT THE ARMRESTS:

- Pull lever (1) backwards to release the system.
- Then, lift the armrest and rotate it backwards.

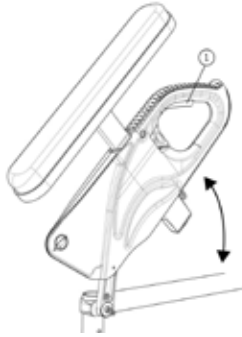

TO REINSTALL THE ARMRESTS IN CLOSED POSITION:

- Rotate the armrests downwards until the front slide plate enters in the armrest socket.
- Make sure the locking lever is engaged to avoid any movement.

7.4.2 REMOVABLE "T" ARMRESTS

TO REMOVE THE ARMRESTS:

- Pull locking lever (1) backwards to release the system.
- Pull the armrest upward.

TO REINSTALL THE ARMRESTS:

- Bring the armrest downward until the slide (2) enters in the armrest socket (3).
- Make sure the locking lever is engaged to avoid any movement.

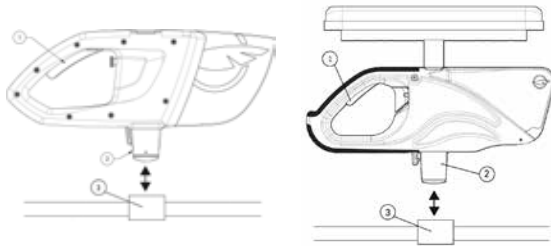

7.4.3 SWING-AWAY "L" ARMRESTS

TO REMOVE THE ARMRESTS FROM THE WHEELCHAIR:

- Lift them straight up to release it from the armrest socket.
- To reinstall the armrests, rotate it to reach its initial position while making sure it is properly inserted in the armrest receiver then back in the armrest socket. (1)

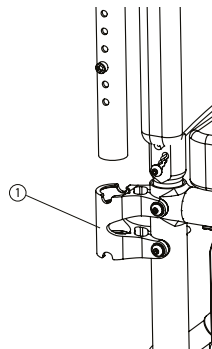

7.5 POSITIONING BELTS

⚠ WARNINGS

Use positioning belts ONLY to help support the user's posture. Improper use of these belts may cause severe injuries to the user.

Make sure the user does not slide down in the wheelchair seat. The pressure exerted by the belt could cause chest compression or suffocation to the user.

Never use wheelchair's belts as a motor vehicle restraint.

- The positioning belt should be used and adjusted in accordance with instructions for use.
- There should be approximately one hand width of space between the positioning belt and thigh, not more than that.
- Make sure the positioning belt is properly fastened as to avoid serious injuries.
- In case of emergency, make sure the positioning belt can be easily unfastened.

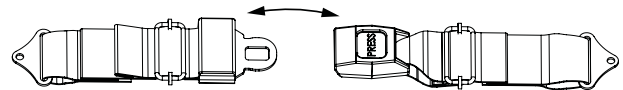

7.5.1 AUTO BUCKLE AND AIRCRAFT BUCKLE POSITIONING BELTS

- To fasten, insert the clip into the buckle until it snaps.
- Make sure the positioning belt is securely fastened.
- To unfasten, lift the flap on the aircraft buckle belt or push the button on the auto buckle belt.
- To adjust your seat belt, pull each strap towards the opposite side until you get the desired tension and keep the buckle centered.

7.5.2 VELCRO™ POSITIONING BELT

- To fasten, insert the long side of the belt into the buckle on the other side.
- Place the other strap of the belt on it and apply pressure on the belt for a firm grip of the Velcro.

7.6 ANTI-TIPPERS

7.6.1 ANTI-TIPPERS

i RECOMMENDATION

Motion Composites strongly recommends the use of both anti-tippers

- Anti-tippers were designed to prevent the wheelchair from tipping backwards.
- To remove or rotate the anti-tippers up, push the release button (1) and pull out or rotate the anti-tippers (2).
- To replace the anti-tippers, press the release button and insert them into the frame until they snap into position.
- Curb Clearance: 1½ in. to 2 in., depending on the configuration.

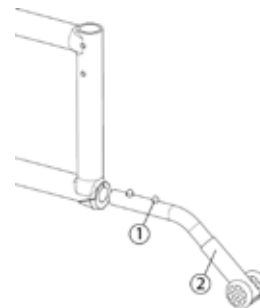

- ⚠ WARNING**
Anti-tippers should not be used as a tipping-aid.
Always install both anti-tippers.

7.6.2 TIPPING-AID LEVER

- ⚠ WARNING**
The tipping lever should not be used with anti-tippers.
- To install or remove the tipping lever, press the release button (1) and push or pull the tipping lever (2).
- When installing the tipping lever, the push-button must snap in position into the frame.
- The tipping lever must be removed when installing anti-tippers.

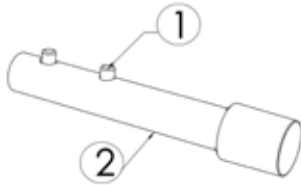

7.7 REAR WHEELS

7.7.1 QUICK-RELEASE AXLES

i INFORMATION
Quick-release axles are provided as a standard wheelchair component. Other axle types are optional equipment.

- ⚠ WARNING**
All quick-release axles are designed to make your rear wheels easy to remove quickly. However, if not used properly, they can be dangerous.
- Never use your chair unless you are sure that both rear axles are locked into place in the axle receiver. If an axle is not fully locked into place, the rear wheel may come off during use of the chair and cause you to fall. You can notice when the axle is locked into place because the quick-release button in the center of the axle will pop out fully. It is recommended to pull on the rear wheel to make sure the axle is securely locked in the receiver.
- To remove the rear wheels, push the button in the center (1) of the quick-release axles and pull the wheels off.
- To reinstall the rear wheels, push the button of the quick-release axles, insert the axle right into the hubs and release the button.
- For safe lock, the detent balls (2) of the axle should protrude outside the axle receiver pin and the inner pin should be at the same level as the axle strap.

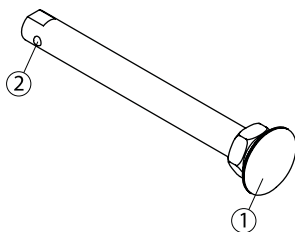

7.7.2 FIXED AXLES

- To remove the rear wheels, unscrew the nut (1) located inside the wheelchair axle bushing and pull out the wheel.
- To reinstall the rear wheels on the wheelchair, insert the threaded axle (2) in the axle bushing, then into the wheelchair.
- Tighten the nut (1) inside the wheelchair. Make sure the tightening does not prevent the wheel from turning properly.

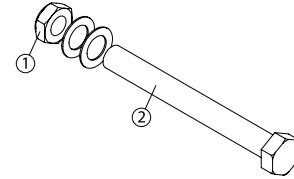

7.7.3 MOTION COMPOSITES ONE ARM DRIVE SYSTEM

USE

- To propel the wheelchair in a straight line, grasp the two handrims in one hand to push or pull in the desired direction.
- To slow down the wheelchair, simultaneously press on the two handrims with one hand to create friction.
- To turn the wheelchair, exert pressure or create friction on one of the two driving handrims.

TO FOLD THE WHEELCHAIR

- Grip the handle (1) and compress the drive shaft (2) on the mounting plate to clear the opposite side of the shaft.
- Remove the drive shaft from the wheelchair and fold it as needed.

TO INSTALL THE ONE ARM DRIVE SYSTEM

- Insert the end of the drive shaft (3) on the mounting plate axle (4).
- Compress the drive shaft and insert the other side of the shaft onto the mounting plate axle on the opposite side.
- Make sure the axle is secure before using the wheelchair.

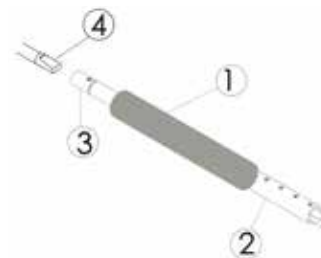

SPECIFICATIONS

- Weight limit: 265 lbs / 120 kg.
- The rear wheels remain attached to the wheelchair.

7.8 SEAT UPHOLSTERY, RIGID SEAT PAN, CUSHION

- Seat upholstery and rigid seat pan is not intended to be used as a seating surface. Always use a cushion.
- Ensure that the seat upholstery and seat base are in good condition (especially with no fraying, no wear and no tears or abnormally stretched material).

7.9 PUSH HANDLES

Push handles are optional equipment on some Motion Composites wheelchairs. Push handles provide secure points for an attendant or assistant to hold the rear of the wheelchair to prevent a fall or tip-over. If you have an attendant or assistant, you should have push handles installed on your wheelchair by Motion Composites or a certified Motion Composites dealer.

- Motion Composites offers push handles that are integrated to the back canes or bolt onto the canes. Motion Composites recommends that you do not use non Motion Composites bolt-on push handles because they could damage the backrest or the back canes of the Motion Composites wheelchair.

- Your attendant or assistant should regularly check the push handles to make sure they fit securely and will not rotate or slip off.
- Push handles should NEVER be used to lift the wheelchair or pull the chair, especially when it is occupied, as they may detach.
- ALWAYS lift or pull the wheelchair by grasping a nondetachable part of the frame (not the detachable handles, backrests, armrests or footrests).
- If you fail to observe these warnings, you may damage the chair; a fall, tip-over or loss of control may occur and cause severe injury to the wheelchair user, the assistants or other people.

7.9.1 FOLD DOWN PUSH HANDLES

Folding Instructions:

- To fold or open push handle, press the button (1) to engage the folding mechanism to fold down or open handles on back canes.
- Weight limit: 120 kg / 265 lb.

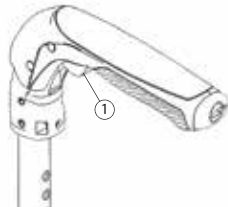

WARNING

Never use the fold-down push handles to lift or pull the wheelchair, especially when it is occupied, as they may detach and cause an accident.

7.9.2 HEIGHT ADJUSTABLE PUSH HANDLES

Adjustment Instructions:

- To adjust the height of the push handles, pull on the lever (1) to open the clamp.
- Set the height and push the lever (1) to close the clamp.
- Weight limit: 265 lbs / 120 kg.

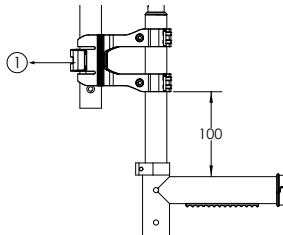

WARNING

Never use the adjustable height push handles to lift or pull the wheelchair, especially when it is occupied, as they may detach and cause an accident.

INFORMATION

The attachment position on the back canes should not be changed. The distance between the adjustable push handle collar and the back canes collar should not exceed 100 mm.

8. ADJUSTMENTS AND MAINTENANCE OF YOUR MOTION COMPOSITES WHEELCHAIR

8.1 SERVICE

Refer to your dealer for servicing your wheelchair. A complete and updated list of service providers can be found on our website.

8.2 REPLACEMENT PARTS

Consult our website to download the parts manual and view ordering information.

Kindly contact us at:

Motion Composites Inc.

160 Armand Majeau Sud, Saint-Roch-de-l'Achigan, Québec, Canada J0K 3H0

Telephone: 1 866 650-6555

Fax: 1 888 966-6555

info@motioncomposites.com

motioncomposites.com

8.3 TOOLS NEEDED

INFORMATION

The Motion Composites wheelchair was designed to be serviced with regular tools. All screws and bolts are standard and can be adjusted with a wrench, socket wrench, or Allen key.

WARNING

Do not use air or electric tool, tightening should be done manually.



The list of tools is at the end of this manual.

8.4 GENERAL MAINTENANCE

8.4.1 TIRE PRESSURE

- Check tire pressure with a tire gage.
- Verify recommended tire pressure as indicated on the sidewalls.
- Inflate if pressure is below recommended amount as labeled on the sidewalls.
- Do not inflate tire over recommended pressure, as stated on the tire.
- Over inflation could result in tire failure and injury.
- An over-inflated tire may cause a tire puncture.

		Max pressure
Pneumatic	1 ³ / ₈ in.	65 psi
Pneumatic HP	1 ¹ / ₂ in. and 1 ³ / ₈ in.	110 psi
Pneumatic HP	1 in.	145 psi

8.4.2 PUNCTURE

In the event of a puncture, consult an appropriate workshop (either a bike repair center or wheelchair repair center) to repair or replace the tube by a qualified person.

8.4.3 CLEANING YOUR WHEELCHAIR

- Use mild clean soap and water to clean your wheelchair.
- Rinse and dry the wheelchair adequately.
- Do not use solvent cleaners.
- Do not use abrasive cleaners
- Do not use a pressure cleaner.

PAINT FINISH AND FRAME

- Clean the painted surfaces with mild soap at least once a month.
- Protect the paint with a coat of non-abrasive auto wax every three months.

AXLES AND MOVING PARTS

- Clean around axles and moving parts weekly with a damp cloth.
- Wipe off dust or dirt on axles or moving parts.

SEAT UPHOLSTERY AND BACK CANES

- Hand-wash only (machine washing may damage fabric).
- Hang to dry only. DO NOT machine dry as heat will damage fabric.

8.4.4 STORING AND SHIPPING YOUR WHEELCHAIR

- When not in use, keep your chair in a clean, dry area. Failure to do so may result in your chair rusting and/or corroding.
- If your chair has been in storage for more than a few weeks, you should make sure it is working properly. You should inspect and service, if necessary, all items in section 11. *Periodic Checklist*.
- If your chair has been in storage for more than two months, it should be inspected by a qualified technician.

- When shipping your wheelchair, use a strong cardboard box to protect the wheelchair from any impact. Inspect the wheelchair once it is received.

8.5 BACKREST

8.5.1 REMOVING/INSTALLING BACKREST

- Remove bolts (1) and (2). Note that in some cases these bolts are also used to support the armrest socket (swing away and flip back armrests).
- Slide the back post upwards to remove it from the tube.
- Reinstall the back post in the reverse order while making sure they are positioned on the right side.
- Tighten bolts (1) and (2) firmly.
- For wheelchairs equipped with flip back armrests; adjust screw (1) while paying special attention to the proper operation of the armrest.

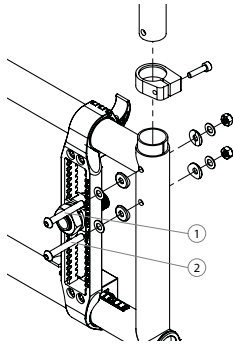

8.5.2 DEPTH ADJUSTABLE OPTION

- Remove bolts (1 and 2).
- Slide the back post forward to remove it from the tube.
- Reinstall the back post in the reverse order while making sure they are positioned on the right side.
- Tighten bolts (1 and 2) firmly.

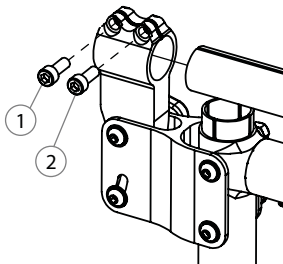

WARNING

Weight Limit: 175 lb (79 kg) and not ISO 7176-19 compatible.

8.5.3 ADJUSTING THE BACK ANGLE

- Loosen screw (1) and remove screw (2) from the leveling device (see Fig. a or b depending on the chair's model).
- Adjust to desired angle using the graduated scale at the lower part of the leveling device.
- Reinstall screw (2) and tighten both screws of the device.
- Adjustments: 5° increments from 85° to 110°.

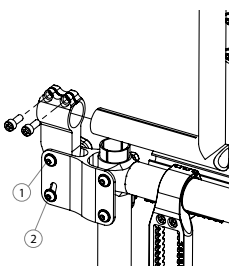

Fig. a

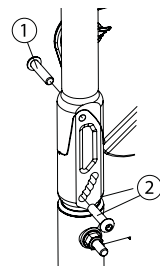

Fig. b

8.5.4 REMOVING/INSTALLING THE POSITIONING BELT

- Remove screw (1) in order to remove the positioning belt clamp (2). (Fig. a)
- Reinstall screw (1) directly on the frame clamp (3) (Fig. b).
- Tighten screw (1) firmly.
- Repeat the same steps on the other side.

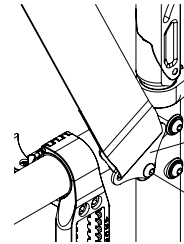

Fig. a

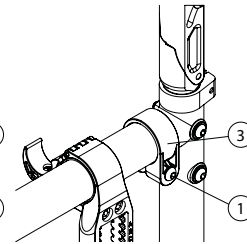
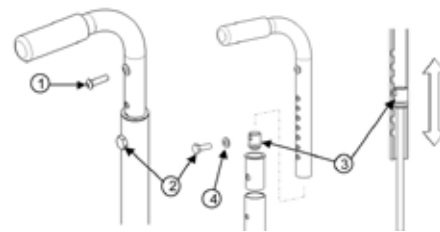

Fig. b

8.5.5 ADJUSTING THE BACKREST HEIGHT

- Loosen the screw (1) that holds the back upholstery.
- Pull backrest upholstery down several centimeters in order to access screw (2) that holds the push handle.
- Remove screw (2) and the backrest handle.
- To adjust the backrest height, move the dowel nut (3), located inside the handle, using a threaded rod (1/4 in.-20).
- Once the dowel nut (3) fits in, use screw (2) to prevent the dowel nut (3) to move when removing the threaded rod.
- Remove screw (2) and reinstall the backrest handle.
- Align screw (2) with the mounting hole.
- Reinstall and tighten screw (2) and the washer (4).
- Repeat the same steps on the other side.
- Reinstall the backrest upholstery with screw (1) and tighten to fit snugly.



8.5.6 ADJUSTING THE 8-DEGREE BACKREST HEIGHT

- The 8-degree backrest can be adjusted by removing the bolt 2 on each side of the frame and by moving the back canes up or down to the desired height.
- Handles and back upholstery will be adjusted accordingly.
- Adjustable angle back canes should not be moved.
- The back upholstery cannot be adjusted on this model.

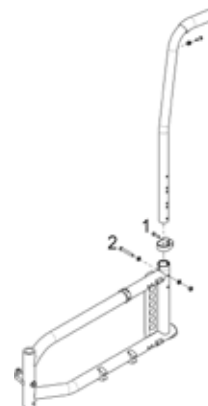

8.5.7 REMOVING/INSTALLING STANDARD BACK UPHOLSTERY

- Removing the screws (1) that hold the back upholstery.
- Pull backrest upholstery down several centimeters in order to access screw (2) that holds the push handle.
- Remove screw (2) and then remove the backrest handle.
- Remove or install back upholstery.
- Once the new back upholstery is installed, reinstall the handles by aligning them with the mounting holes.
- Reinstall and tighten screw (2) firmly.
- Install back upholstery at the adequate position and fix it firmly with screws (1) on each back cane.

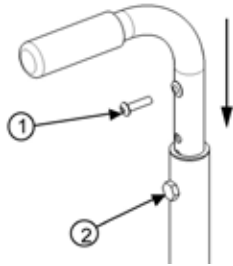

8.5.8 REMOVING/INSTALLING BACK UPHOLSTERY (INTEGRATED PUSH HANDLE)

- Remove screw that holds the back upholstery.
- Remove the 2 bolts on each side of the frame and remove the back canes.
- Remove or install back upholstery.
- Reinstall and tighten screw firmly.
- Install back upholstery and fix it firmly with screw on each back cane.

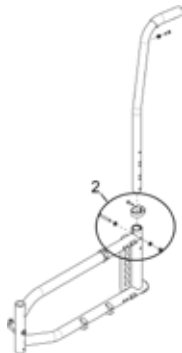

8.5.9 REMOVING/INSTALLING ADJUSTABLE TENSION BACK UPHOLSTERY

- Follow the same steps as when removing the standard back upholstery. Lift the back cover to have access to the 2 bolts to remove the upholstery.
- To adjust the tension, first lift the back cover flap to expose the horizontal straps. Then adjust each strap using the Velcro or the buckle tension adjustment system to the desired tension.



WARNING

AVOID over tightening of strap assembly as this may cause damage to the integrity of back canes.

Complete this adjustment by covering the strap assembly with the back cover flap.

8.6 ARMRESTS

8.6.1 INSTALLING FLIP BACK ARMRESTS

- Insert the flip back pivot (1, 2) and screw it in place, making sure it can rotate easily. (Fig. a).
- Insert the armrest (Fig. b) on the flip back pivot then rotate it until it clicks with the armrest socket (Fig. c); (for clamp installation see 8.6.3 Installing "T" armrests and side guards).

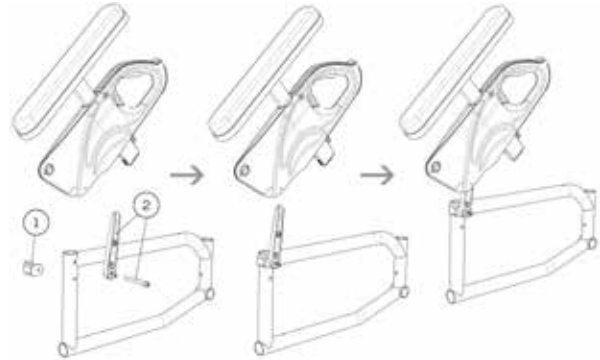

Fig. a

Fig. b

Fig. c

8.6.2 ADJUSTING THE HEIGHT OF FLIP BACK AND "T" ARMRESTS

- Flip lever (1) left or right to unlock the armrest.
- To adjust height, slide the upper part of the armrest into the lower part.
- Slide structure (2) into the slots to adjust to the desired height. Flip the lever back to the closed position. Make sure the armrest clicks in place for complete securement.

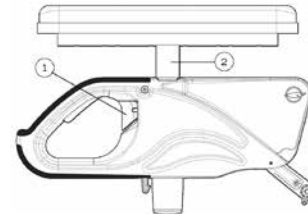

8.6.3 INSTALLING "T" ARMRESTS AND SIDE GUARDS

- Install armrest receiver (1) on the upper tube of the frame at a distance of 160 mm (6 1/4 in.) from the rear tube of the frame.
- Slightly tighten screws (2) to allow the clamp (1) to rotate.
- Insert armrest or side guard into receiver (1).
- Rotate receiver (1) until the side guard is perpendicular to the seat.
- Tighten screws (2) firmly.

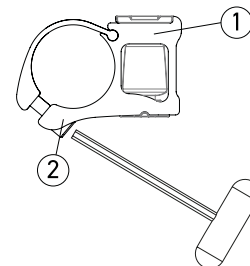

8.6.4 INSTALLING THE SIDE GUARD CLAMPS

- Open the clamp (1) to install it around the back rest in a way that the retaining finger (2) is parallel to back wheels (Fig. a).
- Make sure to place the clamp as high as possible without exceeding the side guard (3), making sure that it is inserted as far into the retaining finger as possible (Fig. b).
- Once in place, secure the clamp by firmly tightening the screw.

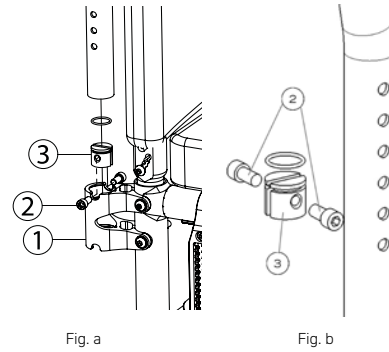
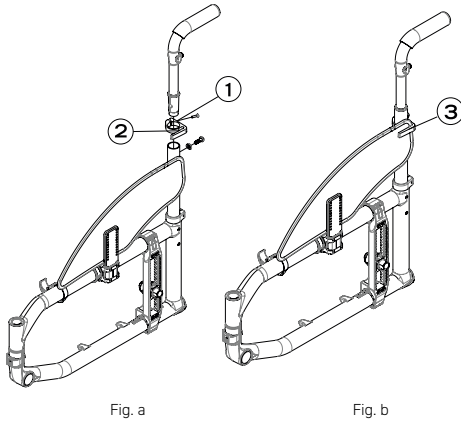

8.7 FOOTREST LENGTH

8.7.1 ADJUSTING FOOTREST LENGTH

- Slightly loosen screw (1).
- Slide the tube to the desired position, within the limits.
- Tighten screw (1) firmly.

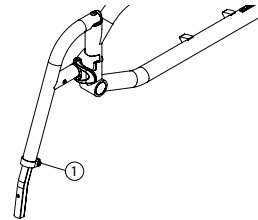

8.6.5 REPLACING ARMREST PAD

- Remove screws (1) located under pad (through the tube).
- Replace with new armrest pad.
- Reinstall screws (1) and tighten firmly.

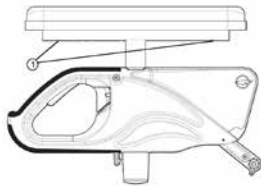

8.7.2 ADJUSTING FOOTREST LENGTH (SWING AWAY TYPE)

- Remove screws on footrests (1).
- Slide the extension tube inside the footrest at the desired length.
- Reinstall screws at desired length.
- Tighten screws firmly.

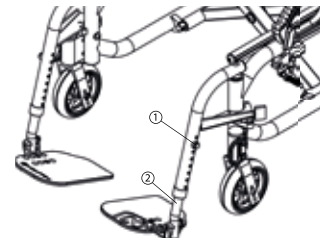

8.6.6 INSTALLING THE SWING AWAY ARMREST RECEIVER

- Remove the two bolts (1).
- Align the armrest receiver with the mounting holes and the backrest frames.
- Reinstall the bolts and tighten firmly.

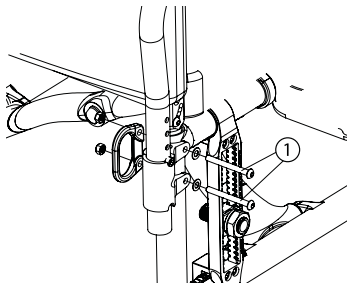

8.6.7 ADJUSTING SWING AWAY ARMREST HEIGHT

- Pull the armrest out of the receiver (1) (Fig. a).
- Unscrew and remove screws (2) (Fig. b).
- Inside the armrest tube, slide the dowel nut with a long flat screwdriver at the desired height (3).
- Reinstall screws (2).
- Reinsert armrest in receiver.

8.7.3 ADJUSTING FOOTREST LENGTH (SINGLE FOOTPLATE TYPE)

- Loosen screws of 5 mm at the bottom of the footrest structure.
- Slide the tube to the desired position, within the limits.
- Tighten screws firmly.

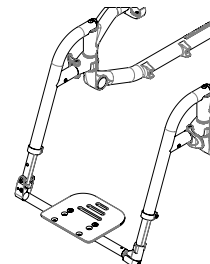

⚠ WARNING
DO NOT remove or unscrew the security screws (pin type)

8.7.4 ADJUSTING FOOTPLATE ANGLE

- Loosen screws (1).
- Rotate the footplate at the desired angle.
- Tighten screws (1) firmly.

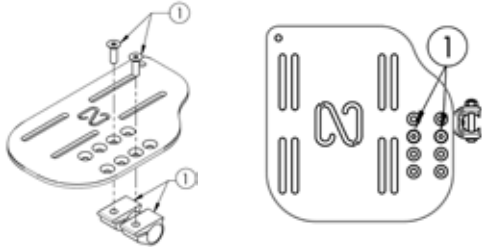

8.7.5 INSTALLING AND ADJUSTING THE LIMB SUPPORT

⚠ WARNING
Never sit on a limb support.

i INSTALLATION
Refer to the installation of footrest in section 7.3 Footrests.

- The limb support can be adjusted horizontally from left to right. In height, it can also be placed closer or farther from the seat and finally the angle may be adjusted.
- To adjust the horizontal alignment from left to right, slightly loosen screws (1), slide the cushion horizontally to the desired position, then tighten the screws at a torque of 7 Nm.
- To adjust the limb support's angle, slightly loosen screws (1), place the cushion at the desired angle, then tighten the screws at a torque of 7 Nm.
- To adjust the support in relation to the seat, slightly loosen the screws under the cushion (2), slide the support into the desired position and then firmly tighten the screws.
- To adjust the height, slightly loosen the screws (3) to allow the clamp to slide on the vertical axle. Slide the limb support into the desired position and then tighten the screws at a torque of 7 Nm.
- To adjust the base rotation, slightly loosen the screws (4) to be able to rotate the clamp on the main axle. Rotate the limb support into the desired position, then tighten the screws at a torque of 7 Nm.

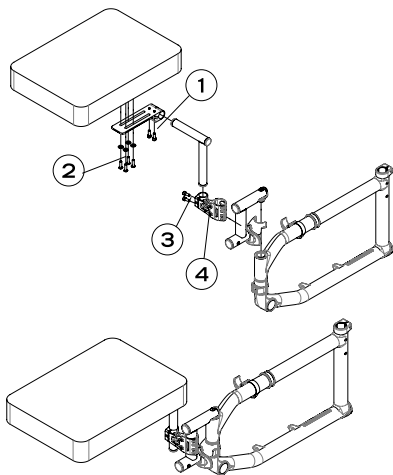

i RECOMMENDATION
It is easier to adjust one axle at a time.

8.7.6 CLEANING THE LIMB SUPPORT

To clean the limb support, remove the cover and follow the same instructions as in the section 8.4.3 *Cleaning your wheelchair* for the seat cover and back rest.

8.8 SEAT

It may be difficult to unfold the wheelchair if the seat upholstery has been installed too tight.

8.8.1 REPLACING SEAT UPHOLSTERY

SLIDE-ON SLING

- Partially close the wheelchair to remove tension in the seat upholstery.
- Remove end cap (1).
- Remove old seat upholstery and slide in new seat upholstery.
- Reinstall end cap (1).
- Adjust tension with the Velcro located under the seat pad.
- Fully open the wheelchair and make sure the upholstery is tight.

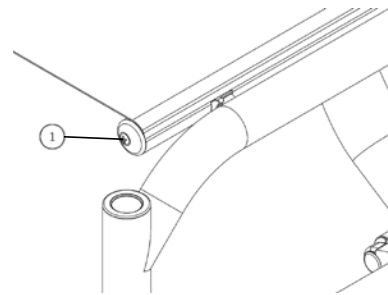

8.8.2 REPLACING THE RIGID SEAT

INSTALLATION

1. Place the back edge on the frame so that it engages the back rest clamp on both sides.
2. Lower the front edge so that it rests on the frame and press firmly on both sides.
3. Check that the seat plate is properly installed by trying to pull it forward and to the sides. A properly installed plate should not move and should remain fixed in its position. If the plate moves or slips out of position, check that the edge of the rear installed plate is marked with the digit 1 then, repeat steps 1, 2 and 3.

There is a sticker on the bottom of the plate identifying the edges and indicating the steps.

To remove the plate, simply lift the front edge to disengage the clips.

⚠ WARNING
Never place the seat plate with the edge identified by the digit 1 in front.

8.9 SEAT-TO-FLOOR HEIGHT

⚠ WARNING
Any change in the floor/seat height requires an adjustment of the anti-tippers, the caster housing angle and the 3° and 6° axle receivers. It is important to make these adjustments before using the wheelchair to avoid the risk of injury.

8.9.1 CHANGING THE FRONT SEAT-TO-FLOOR HEIGHT

To change the front seat-to-floor height, you can do one of these three things:

- Move casters into forks.
- Install different caster size.
- Change caster housing fork stem with the necessary spacers (Standard, +2.5 cm (1 in.) and 5cm (2 in.) available).

8.9.2 CHANGING REAR SEAT-TO-FLOOR HEIGHT

To change the rear seat-to-floor height, you can do one of these two things:

- Install the rear wheel axle bushing receivers in a different position along the rear mounting plate.
- Install different rear wheel size.

8.9.3 CHANGING FRONT & REAR SEAT-TO-FLOOR HEIGHT

To change the front and rear seat-to-floor height simultaneously, you can:

- Change seat cushion thickness.

8.10 CASTERS, FORKS AND FORK STEM ASSEMBLIES

8.10.1 REMOVING/INSTALLING/REPOSITIONING CASTERS

- Loosen and remove bolt (1).
- Remove, install or reposition the caster.
- Place spacers (2) between the caster and the fork.
- Tighten nut (3) firmly.

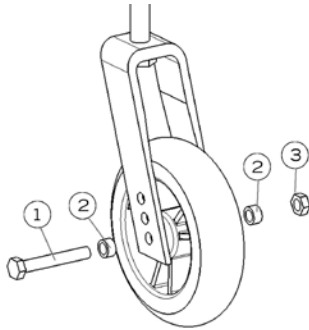

8.10.2 REMOVING/INSTALLING THE CASTER HOUSING (C2)

TO REMOVE

- Remove the screw (1).
- Remove the screw (2).
- Slide the caster out of the frame.

TO REINSTALL

- Slide the caster housing plug in the frame.
- Reinstall caster housing (2).
- Reinstall screws (1).

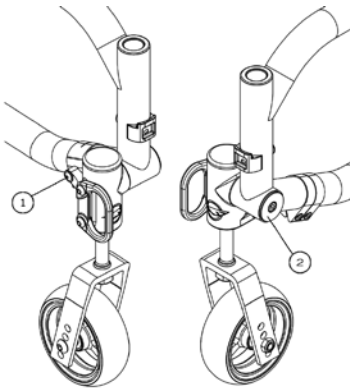

i **INFORMATION**
To change the stem bolt or service the bearings, always remove the caster housing from the frame.

8.10.3 REMOVING/INSTALLING CASTER HOUSING (A6)

TO REMOVE

- Note the position of the notch on the inserts.
- Remove the screws (3, 5).
- Remove eccentric inserts (2), caster housing (1), spacer (4) and threaded plug (6).

TO REINSTALL

- Slide in the spacer (4), caster housing (1) and eccentric inserts (2) and threaded plug (6)
- Position eccentric inserts as they were before removal or adjust caster housing angle correctly.
- Apply medium strength thread locker (blue Loctite) and reinstall the screws (3) and apply a torque of 12 Nm.
- Apply medium strength thread locker (blue Loctite) and reinstall the screw (5) and apply torque of 7 Nm.

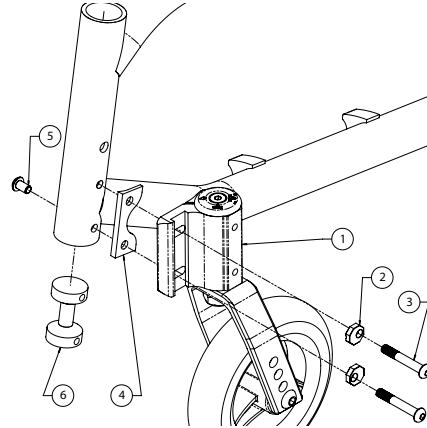

i **INFORMATION**
To change the stem bolt or service the bearings, always remove the caster housing from the frame.

⚠ **WARNING**
Avoid overtightening the screw. Excessive tightening can damage the anti-flutter system.

8.10.4 CHECKING/ADJUSTING CASTER HOUSING ANGLE (C2)

⚠ **WARNING**
Transit securement points are to remain in their original positions. Transit securement points are only designed to be used in their original position facing forward. Do not rotate transit securement points inward.

- Position the wheelchair so that the 4 wheels are on the ground.
- Use a set square and place it on the ground and along the caster housing (1).
- The caster should be parallel to the set square.
- If the housing is not parallel to the set square, remove the screws (2) and loosen the screw (3).
- Loosen the screw slightly (4) to allow the clamp (5) to move.
- If the clamp (5) does not slide on the frame, loosen the screw (4) completely.
- Rotate the caster housing to adjust the angle.
- Tighten the screw (3).
- Make sure the caster housing is remains perpendicular to the ground.
- Tighten screws (2) again, (4) alternately and securely. For final tightening of the screws (2), torque to 12 Nm.

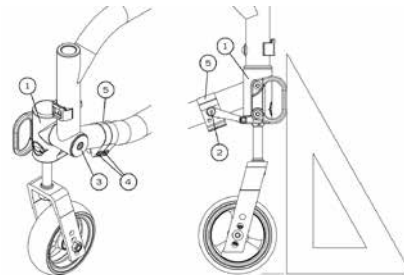

8.10.5 CHECKING/ADJUSTING CASTER HOUSING ANGLE (A6)



WARNING

Transit securement points are to remain in their original positions. Transit securement points are only designed to be used in their original position facing forward. Do not rotate transit securement points inward.

All four wheels should be touching the floor.

- Use a set square and place it on the ground and along the caster housing.
- The housing should be parallel to the set square.
- If the housing is not parallel to the set square, loosen screws (2) sufficiently to remove the eccentric inserts (3) from the caster housing (1).
- Rotate the caster housing to adjust the angle.
- Replace the eccentric inserts (3) into the housing and tighten screws (2).
- Check again that the caster housing is perpendicular to the ground by using the set square.
- For final tightening of the screws (2), torque to 12 Nm.

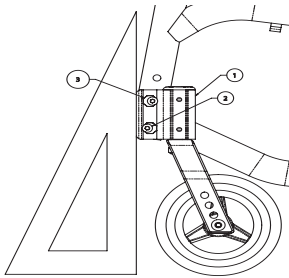

8.10.6 REMOVING/INSTALLING FORK STEM ASSEMBLIES

TO REMOVE THE STEM FORK:

- Remove the screw (1) and washer (2) while holding the fork.
- Remove the wheel assembly, fork and stem.
- It may be necessary to remove the wheel to remove the fork stem (7).
- Remove the nut (8) while holding the stem (7) by the flat parts with a wrench.
- Remove the fork and do any required maintenance.

TO INSTALLING THE STEM FORK:

- Refer to the diagram to make sure all hardware is installed in right order.
- Insert the stem (7) into the fork (not showing) and tighten the locknut (8) to 29.3 Nm while holding the stem (7) with a wrench.
- Slide the dust protector (9) onto the stem (7).
- Insert the wheel, fork and threaded rod assembly through the caster housing. Make sure the arrow on the friction cap (4) points to the groove in the caster housing (6) before the next step.
- Tighten the screw (1) and washer (2) while holding the fork (not showing) from under to prevent it from turning.
- Adjust the caster flutter by turning the adjustment screw (3).

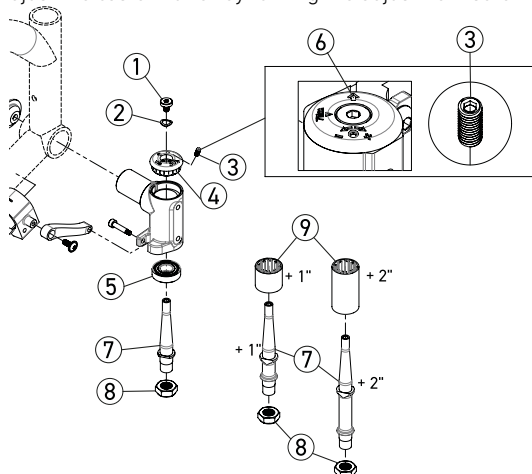

INFORMATION

The adjustment screw is used to add friction to the stem to reduce wheel flutter.



WARNING

Avoid over tightening the screw. Overtightening may damage the anti-flutter system.

8.11 REAR WHEELS

8.11.1 ADJUSTING QUICK-RELEASE AXLES

- Remove the rear wheel from the wheelchair.
- Behind the quick-release button, there is a nut that adjust the length of the axle.
- Hold the axle with a wrench at the other end (near the detent balls) and turn the bolt to increase the length or tighten to shorten the axle.
- Reinstall the pull button onto the wheel and in the axle bushing receiver on the wheelchair.
- To ensure a secure lock, the quick-release locking balls must extend beyond the axle receiver.

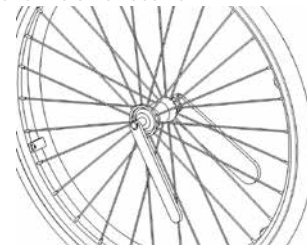

8.11.2 REPLACING/ADJUSTING HANDRIMS

- On the Newton One wheel, the tire may stay in position.
- Use a plastic tire removal tool to take off the tire (1).
- Remove all nuts (2) inside the rim (3).
- Replace the handrim (4) with a new one and align the mounting holes (5).
- Reinstall and tighten the bolts (2) firmly.
- Reinstall the tire (1) on the rim.

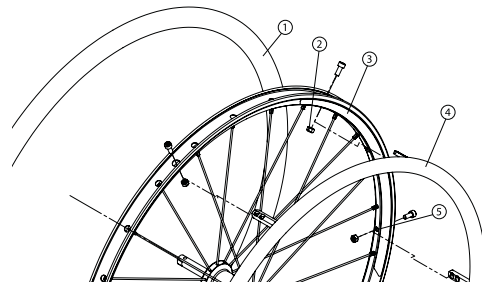

8.11.3 ADJUSTING THE REAR AXLE HEIGHT (C2)

- Loosen the nut holding the axle bushing (3).
- Move the axle bushing (1) along the mounting plate (2).
- Reinstall the bushing in the desired mounting hole and tighten nut (3).

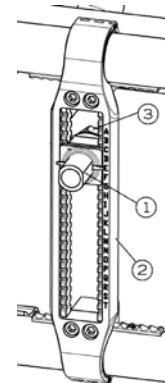

8.11.4 ADJUSTING THE REAR AXLE HEIGHT (A6)

- Remove the nut (3) holding the axle bushing.
- Move the axle bushing (1) along the mounting plate (2).
- Reinstall the bushing in the desired mounting hole and tighten nut (3).

WARNINGS

The seat height, seat depth, back angle, seating system/upholstery, size/position of the rear wheels, size/position of the casters, as well as the user condition directly relate to the stability of the wheelchair. Any change to any of these combinations may reduce the wheelchair's stability. These adjustments must be performed by a qualified technician.

The seat-to-floor height must have a specific position depending on the rear wheel size, rear wheel position, front caster size/position and seat-to-floor angle. These adjustments must be performed by a qualified technician.

8.11.5 ADJUSTING REAR WHEEL SPACING

- The rear wheels can be adjusted laterally by repositioning axle receiver (1) on mounting plates (2).
- Loosen nuts (3) on axle receivers (1).
- Position nuts (3) to adjust the spacing.
- Tighten the nuts (3) firmly.
- The nut can be switched from side to side for more adjustments.

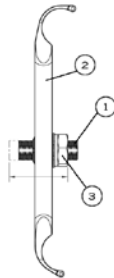

8.11.6 CHANGING REAR CAMBER

MICRO-ADJUSTMENT V2 MOUNTING PLATE

- Note the position of face plates (4) on mounting plate.
- Remove nut (1) and lock washer (2) holding the axle bushing (3).
- Remove the axle bushing (3) along the mounting face plates (4).
- Change or replace the 0° or 3° axle bushing (3).
- Change or replace the 0° or 3° mounting face plates (4) to reach a 0°, 3° or 6° angle.
- Reinstall axle bushing, mounting face plates, lock washer and nut at the desired position on the V2 mounting plate.
- Adjust the toe-in / toe-out of rear wheels.
- Tighten the nut (1) on the mounting plate on the right and left side of the wheelchair.

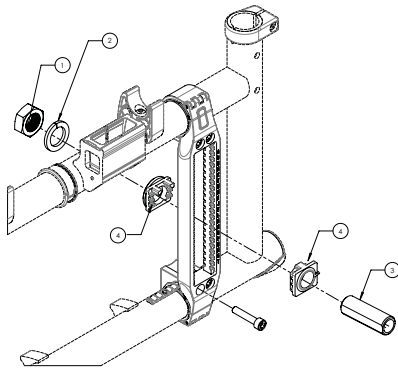

STANDARD T2 MOUNTING PLATE

- Note the position of the axle bushing (3) on the mounting plate
- Remove the 2 nuts (1) and lock washer holding the axle bushing (3).
- Remove axle bushing (3).
- Change or replace the 0° or 3° axle bushing (3).
- Reinstall axle bushing, the lock washer and nuts at the desired position on the T2 mounting plate.
- Adjust the toe-in toe-out of the rear wheels.
- Tighten the nut (1) on the right and left sides of the wheelchair's mounting plate.

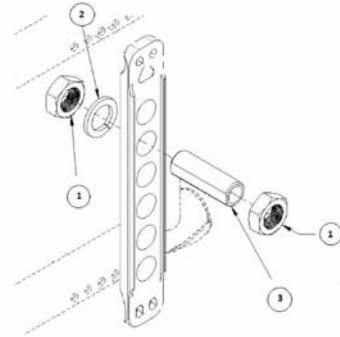

8.11.7 ADJUSTING THE CENTER OF GRAVITY

- Remove the rear wheel.

MICRO-ADJUSTABLE AXLE-PLATE (C2)

- Remove the 4 bolts (1) on the axle plate.
- Move the axle plate to the desired position
- Reinstall the 4 bolts (1) on the axle plate and torque to 12 Nm.

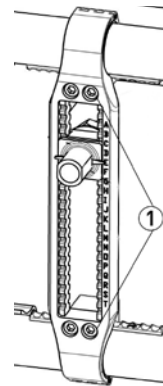

STANDARD AXLE PLATE (A6)

- Remove the 4 bolts (1) on the axleplate
- Move the axle plate and double nut plate on the opposite side of the frame tube to the desired position.
- Reinstall the 4 bolts (1) on the axle plate and torque to 7 Nm.

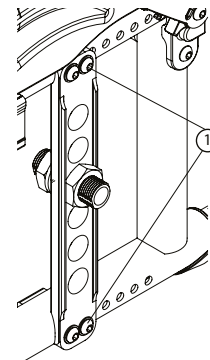

8.12 WHEEL LOCKS

8.12.1 REPLACING/ADJUSTING THE WHEEL LOCK

- Loosen the two screws (1).
- Slide the wheel lock system to the desired position.
- Tighten screws (1) firmly. Final tightening should be done manually.
- Once engaged, the wheel lock stem should embed 3 mm into the tire.

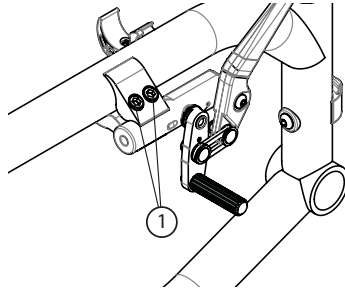

8.13 WHEEL LOCK EXTENSIONS

8.13.1 REPLACING/ ADJUSTING WHEEL LOCK EXTENSIONS

- Loosen screw (1) completely.
- Align eyelet (2) with the mounting hole.
- Re-tighten lever screw (1) on the wheel lock.

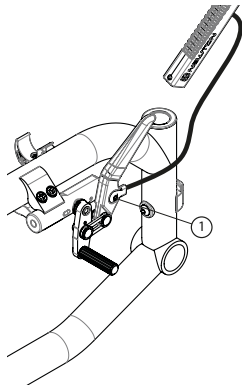

8.14 ANTI-TIPPERS

8.14.1 ADJUSTING THE HEIGHT OF ANTI-TIPPERS

Both anti-tippers must be used with your wheelchair at all times. Though optional, Motion Composites strongly recommends ordering anti-tippers as they are an important safeguard for the wheelchair user. Always use anti-tippers.

- The anti-tippers should be between 4 cm to 5.1 cm (1½ in. to 2 in.) off the ground.
- Improper spacing may result in wheelchair hang ups over obstacles or preventing the wheelchair from tipping over.
- Press the push-button (1) and slide anti-tippers' extensions to the desired length.
- Ensure the button snaps back into place.

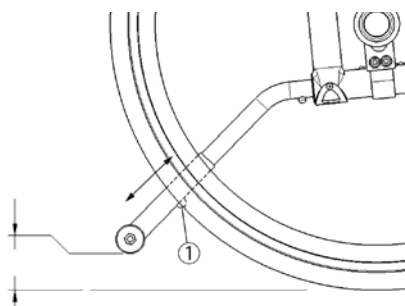

i INFORMATION

If you are unable to adjust the current anti-tippers to the proper height, contact your Motion Composites dealer to replace your anti-tipper for another size.

8.14.2 TIPPING AID

- The assistant can tip the wheelchair more easily to navigate over obstacles with a tipping aid.
- Hold the wheelchair by the push handles.
- Press the tipping aid with your foot and hold the wheelchair in the tipped position until you have overcome the obstacle.

INSTALLATION:

- Press the push-button on the tipping aids to remove it.
- Insert the tipping aid lever by pressing the push-button and sliding it in position,

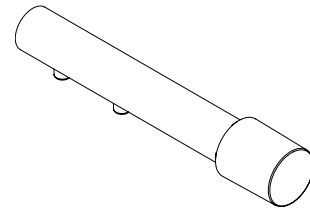

CAUTION-RISK OF TIPPING OVER

Always reinstall anti-tippers when the tipping aids are not in use.

8.15 HEADREST KIT AND HEADREST SUPPORT

8.15.1 INSTALLING A HEADREST SUPPORT

- Must be installed only on HD push handles.
- Cut the end of the push handle with a knife to be able to see the inside of the tube.
- Insert a 0.25 -20 in. (1) roll pin with the fastening device (2) inside the handle (40 mm).
- Install the anchor system of the headrest support by tightening it in the 0.25 -20 in. roll pin.

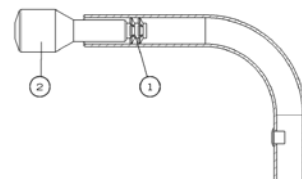

8.15.2 INSTALLING HEADREST KIT

- Once the headrest support is installed, insert the adjustable headrest height into the horizontal stem then replace it.
- Install headrest kit on the ball pivot and tighten the three screws (1) alternately.
- Once the final adjustment is completed, firmly tighten all parts.

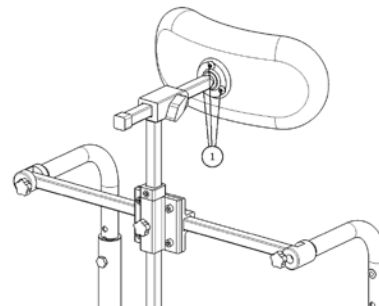

8.16 AMPUTEE AXLE PLATE

8.16.1 INSTALLING AN AMPUTEE AXLE PLATE (C2)

- Install the back clamp (3) onto the rear of the frame.
- Install mounting plate (1) by closing the clamps on the frame.
- Insert a second axle receiver (2) on the axle plate.
- Insert the axle bushing (8) through axle plate (6) and in the two axle receivers (2).
- Install it with the nuts and the washers (4) (5).
- Insert two screws (7) into amputee axle plate through the mounting clamp and tighten.
- Insert axle receiver (8) in the amputee plate and tighten nuts (9).

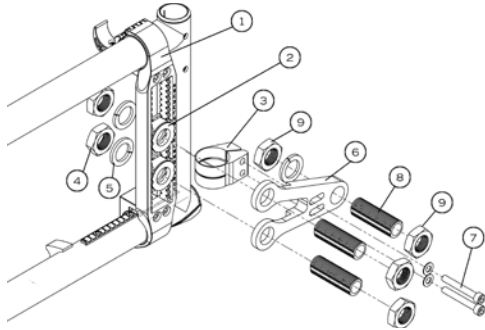

8.16.2 AMPUTEE AXLE PLATE (A6)

- Install the rear clamp (2) onto the rear of the frame.
- Install mounting plate (1) by bolting it to the frame.
- Insert 4 amputee plate adapters (3) on the mounting plate (1) at the desired position.
- Insert both bolts (4) and washers (5) into the rear clamp (2) through amputee plate (6) and tighten.
- Insert rear wheel mounting axle (7) through the amputee plate and insert nuts (8) and lock washers (9).
- Insert 2 bolts (10) through the mounting and amputee plate (1 and 6) then, tighten with nuts (11).

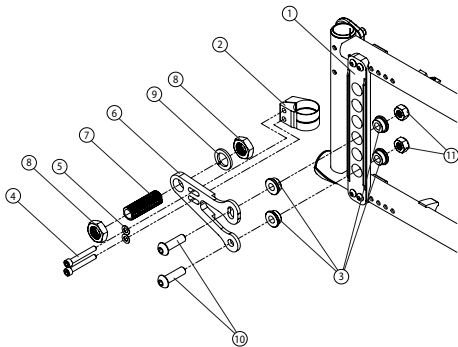

8.17 CENTER OF GRAVITY EXTENSION PLATE

8.17.1 CENTER OF GRAVITY FORWARD EXTENSION PLATE (C2)

- Install mounting plate (1) by closing the clamps on the frame.
- Insert a second axle receiver (2) on the mounting plate.
- Insert two axle bushing (8) through the adjustment plate CG (6) and in the two axle receivers (2).
- Install it with nuts and washers (4) (5).
- Insert the third axle bushing (8) in the adjustment plate CG (6) and tighten the three nuts (9).

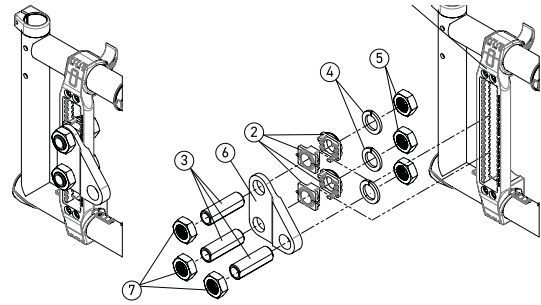

8.17.2 CENTER OF GRAVITY FORWARD EXTENSION PLATE (A6)

- Install mounting plate (1) by bolting it to the frame.
- Insert 4 amputee plate adapters (2) on the mounting plate (1) at the desired position.
- Insert 2 amputee plate adapters (2) on the adjustment plate CG (6).
- Insert the two screws (3) through the adjustment plate CG (6) and mounting plate (1).
- Install it with nuts (5).
- Insert the axle bushing (7) through adjustment plate CG (6) and install with the nut (4) and the lock washer (8).

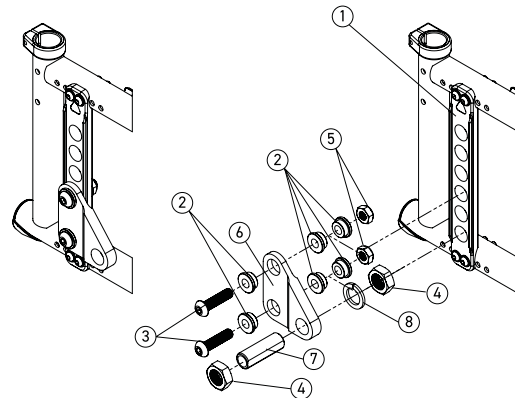

8.18 USING OCCUPIED TRANSIT TIE DOWN SYSTEM



WARNING

To reduce risk of injuries, Motion Composites recommend that wheelchair users should not be transported while sitting in a wheelchair regardless the vehicle type.

Motion Composites recognizes that the safest transit option for a wheelchair user is to transfer in an appropriate seat of the vehicle and to use the motor vehicle restraint system. Motion Composites cannot, and does not, recommend any particular fastening system for wheelchair paratransit.

The standard wheelchair positioning belt should never be used as a safety seat belt when sitting in a paratransit vehicle.

Transit regulation may vary in different legislation, states, provinces and countries. Only use a transit tiedown system that is approved by legislation.

To avoid risk of injuries, remove all objects or accessories from the wheelchair that are not installed onto the chair then, store them securely in the paratransit vehicle.



WARNING

Identify whether your wheelchair was manufactured with the Paratransit Option installed.

If your chair is not equipped with the Paratransit Option:

1. Never let anyone sit in this chair while in a moving vehicle.
 - a. Always move the user to an approved motor vehicle seat.
 - b. Always secure the user with proper motor vehicle restraints.
2. In case of an accident or sudden stop, the user can be ejected from the chair. The wheelchair positioning belts cannot prevent these movements, and the wheelchair belts or straps could cause injury.
3. Never transport in the front seat of a vehicle. It could move and interfere with the driver.
4. Always secure this wheelchair so that it cannot roll or shift.
5. Do not use any wheelchair that has been involved in a motor vehicle accident.

If you fail to heed these warnings, damage to your wheelchair, a fall, tip over or loss of control may occur and cause severe injury to you or to others.

WARNING

If the wheelchair is equipped with the anchor system ISO 7176-19 for paratransit, you must read the instructions for using ISO 7176-19 fasteners at the end of this manual.

9. MOTION COMPOSITES LIMITED WARRANTY

Refer to the Motion Composites warranty document.

IMPORTANT NOTICE REGARDING CONSUMERS RIGHTS

The benefits we give in this manufacturer's warranty are additional to, and do not detract from, any rights and remedies that you may have under local consumer protection laws in your locality.

This warranty is governed by the laws of the country, province, State or territory where you purchased your Motion Composites product. In many countries, consumers have statutory rights under local consumer laws. Those consumer rights may differ between countries, territories, States or provinces, and often cannot be excluded. This Manufacturer's warranty is not intended to:

- change or exclude any statutory consumer rights that cannot be lawfully changed or excluded; or
- limit or exclude any right you have against the person who sold the Motion Composites product to you if that person has breached their sales contract with you.

OUR RESPONSIBILITY

Motion Composites' sole obligation and your exclusive remedy under this warranty shall be limited to such repair and/or replacement.

WARRANTY SERVICE

If your wheelchair requires warranty service, kindly contact an authorized Motion Composites Distributor in Canada or any Authorized International Distributor. In the event of a defect in material or workmanship, the Distributor must obtain a return authorization (RA) number from Motion Composites. Motion Composites issues RA numbers only to authorized Motion Composites Distributors.

If you are not satisfied with a service, kindly write to the customer service at:

Motion Composites Inc.
160 Armand Majeau Sud, Saint-Roch-de-l'Achigan,
Québec, Canada J0K 3H0

Telephone: 1 866 650-6555
Fax: 1 888 966-6555

info@motioncomposites.com
motioncomposites.com

or send an email at:
service@motioncomposites.com

IMPORTANT NOTICE

Do not return products to our factory without our prior consent.

CONSUMER NOTICE

1. The foregoing warranty is exclusive, and in lieu of all other express warranties, whether written or oral, express or implied. Motion Composites shall not be liable for any consequential or incidental damages whatsoever. By registering your Motion Composites wheelchair, you agree with all provisions of this warranty.
2. It is forbidden to alter or extend the foregoing express warranty or to waive any of the limitations or exclusions.

10. PARTICULAR DAMAGES

10.1 PARTS REPAIRED BY THE SERVICE CENTER

If any of the following conditions are observed, the user is responsible for taking the wheelchair to their service center for servicing.

- Wheel adjustment
- Defective ball bearings of caster housings
- Defective ball bearings of casters

10.2 SPECIAL CONDITIONS FOR RETURNING THE WHEELCHAIR TO THE MANUFACTURER

If any of the following conditions are observed, the user is responsible for contacting their qualified service agent prior to sending their wheelchair for repairs at Motion Composites.

- Part of the frame or cross brace is cracked.
- The thread of a rivet-nut is damaged.
- Part of the frame or the cross brace is detached.
- Cross brace becomes abnormally worn.
- Problems continue to be identified after several adjustments or repairs have been made by a qualified service agent.

10.3 REPAIR PROCEDURE

Parts that could be repaired by the owner:

- Rear tire and inner tube.

Parts serviced by the manufacturer or service center:

- All parts of the wheelchair except for the tires and the inner tubes.
- Parts that can be removed and sent to the manufacturer/distributor or other service center for repair: wheels, armrest, footrest, upholstery, cushion.

Conditions in which the wheelchair should be sent for service:

- Broken bearings, loose spokes, wheels not aligned, loose bolt, abnormal vibrations, noise or any deviation in the frame, front stem is not perpendicular to floor, broken part like anti-tippers, back canes, rips or tear on the upholstery and for the yearly inspection.
- Please contact our customer service agent for the complete list of distributors or service centers at: motioncomposites.com
- Some dealers may offer replacement units during the service period. Please contact your service agent for full details. Motion Composites will hold replacement parts for a minimum of 10 years or propose a compatible spare option.
- If the wheelchair needs to be sent to a service center or to the manufacturer for repair, it should be packed carefully in a cardboard box fitting the size of the wheelchair. The anti-tippers, the footrest and cushion should be removed and packed in a small box inside the smaller box inside the cardboard containing the wheelchair. The wheelchair should be protected with a protective film to prevent from scratches or wear.

10.4 TOOLS

ALLEN KEYS

2 mm – 2.5 mm – 3 mm – 4 mm – 5 mm

KEYS

10 mm – 11 mm – 1/2" (13 mm)

FOR QUICK RELEASE

7/16" (11 mm) – 3/4" (19 mm) – 26 mm

OTHER TOOLS

Adjustable wrench – Phillips screwdriver

11. PERIODIC CHECKLIST

AT EVERY USE

- Make sure wheelchair rolls easily and straight.
- Check for noise, vibration or any deviation from normal functioning.
- Make sure wheel locks are working properly.
- Make sure the two quick release axles of rear wheels are locked.
- Make sure the front forks are perpendicular to the floor.
- Visually inspect tires (front & rear) for debris, low pressure, puncture or wear.
- Make sure anti-tipper are locked in lower position (if equipped).
- Visually inspect fabric for wear, tears and cuts.
- Make sure that handles are not loose (if equipped).
- Check handrims for rough edges and make sure they are free from grease or other contaminants.
- Checks for component interference.
- Check for irregular noise and rattles.

WEEKLY

- Check tire pressure with a tire gage.
- Check seat upholstery tension.

MONTHLY

- Check wheel alignment.
- Check for free running of forks.
- Inspect bolts and screws and tighten if necessary.

YEARLY

- Have a complete inspection performed by a qualified technician.

i IMPORTANT INFORMATION

Tire pressure could be adjusted by the owner or an assistant with proper tools. If any part appears not to work properly after inspection, the wheelchair should be immediately sent for repair to a qualified technician.

i NOTICE FOR DISPOSAL OR RECYCLING OF THE WHEELCHAIR

To be disposed of the chair, return the device to your dealer or rehabilitation center.

All components of the product should be recycled or disposed in accordance with national environmental laws and standards.

12. DECLARATION OF CONFORMITY

ADDRESS OF PRODUCT OWNER

Motion Composites
160 Armand Majeau, sud, St-Roch-de-l'Achigan
Québec, Canada J0K 3H0

Telephone: 1 866 650-6555

Fax: 1 888 966-6555

info@motioncomposites.com

motioncomposites.com

AUTHORIZED REPRESENTATIVE

Advena Ltd.
Tower Business Centre, 2nd Flr.
Tower Street, Swatar, BKR 4013, Malta

We hereby declare that the below mentioned devices have been classified according to the classification rules and conform to the Essential Principles of Safety and Performance as laid out in the Health Products Regulations BNQ 6645-001 and ISO 7176-19.

MEDICAL DEVICES

Motion Composites HELIO C2, A6, manual wheelchairs.

MANUFACTURE SITE

Motion Composites Inc.
160, Armand-Majeau Sud, Saint-Roch-de-l'Achigan
Quebec, Canada J0K 3H0

RISK CLASSIFICATION

Class 1 Medical Device (per DORS/98-282).

STANDARDS APPLIED

- NF EN ISO 7176-1:
Wheelchairs, part 1: Determination of static ability.
- NF EN ISO 7176-5:
Wheelchairs, part 5: Determination of dimensions, mass and maneuvering space.
- NF EN ISO 7176-8:
Wheelchairs, part 8: Requirements and test methods for static, impact and fatigue strengths.
- NF EN ISO 7176-11:
Wheelchairs, part 11: Test Dummies
- NF EN ISO 7176-15:
Wheelchairs, part 15: Requirements for information disclosure, documentation and labeling.
- BNQ 6645-001
- ISO-7176-19

This declaration of conformity is valid from 2020/05/21.



ISO 7176-19 OCCUPIED TRANSIT ANCHOR KITS



WARNING

Read all these pages before using the Motion Composites wheelchair transit tiedowns. Use equipment that meets RESNA WC-4:2017, Section 19 or ISO 7176-19:2019 standards and use it according to the instructions. Use only original wheelchair parts and a recognized safety belt system. Use appropriate occupied transit anchor kit and according to instructions. Avoid using the wrong equipment or attaching other equipment to the wheelchair.

The following information pertains to Motion Composites wheelchairs equipped with a factory-installed RESNA WC-4:2017, Section 19 or ISO 7176-19:2019 occupied transit anchor kit. Read this manual completely before using the wheelchair with the occupied transit anchor kit in a motor vehicle. If you have any questions about this manual or about using your wheelchair as a seat in a motor vehicle, contact your Motion Composites Rehab Specialist.



WARNING

AVOID IMPROPER USE OF THIS EQUIPMENT.
AVOID ATTACHING ANY OTHER EQUIPMENT, OTHER THAN THOSE DESCRIBED IN THIS MANUAL, TO A MOTOR VEHICLE.

1. INTRODUCTION

Motion Composites wheelchair is available with an occupied anchor kits conforming to the requirements of RESNA WC-4:2017, Section 19 or ISO 7176-19:2019 for occupied transit. This option is only offered as a factory-installed option.

The occupied transit anchor kits option has been tested in accordance with RESNA WC-4:2017, Section 19 ("WC19") frontal impact test and also tested in accordance with ISO 7176-19:2019, with a 169.4-lb. (77 kg) surrogate occupant to be compliant with a user weight range of 23 to 120 kg (51 to 265 lb). The Motion Composites occupied transit anchor kits meet these standards to enable wheelchairs to be more appropriately secured in a paratransit vehicle. The occupied transit anchor kits options consist of four

mounting brackets factory-installed on the wheelchair. Only use the designated anchor points to secure the wheelchair to the vehicle. In some markets, the kits may be offered with an optional wheelchair anchored pelvic safety belt. Always use this optional belt with the vehicle anchored chest safety belt. The optional wheelchair anchored is only available for purchase from Motion Composites and only available as a Motion Composites factory-installed option. If this option is not present, always use the vehicle anchored three-point safety belt. NEVER rely on a positioning belt during occupied transit. The option is approved for use in occupied transit use. Therefore, users of the occupied transit option should keep several considerations in mind. First, the tests are conducted in manner where the wheelchair is secured in a forward-facing position for a frontal collision at 30 mph (48 km/h). The standards do not test for wheelchair performance in any other type of collision, including, without limitation, side impacts, rear impacts, rollovers, or higher speed frontal impacts. Second, compliance with either standard does not guarantee that the occupant will not be injured, even in a frontal impact collision at 48 km/h (30 mph) or less. In such an impact, the forces experienced are very large and injuries can occur, even if the wheelchair performs exactly as required by the standards.

As a result, Motion Composites always recommends that the wheelchair user should transfer to the motor vehicle seat and use the vehicle-installed restraint system whenever it is feasible.

A wheelchair UNOCCUPIED transit option is also available on the market for some Motion Composites wheelchairs. This UNOCCUPIED wheelchair transit option has not been crash-tested. This wheelchair transit option only includes four tiedown brackets. This option shall be used only for transiting an UNOCCUPIED wheelchair.

If you are not certain that an occupied transit anchor kit is installed on your wheelchair, please contact Motion Composites customer service. Kindly contact Motion Composites customer service with any questions you may have regarding the use of this wheelchair for occupied transit in a motor vehicle at the following number: 1 866 650-6555.

DO NOT have your wheelchair altered in any way by a non-authorized Motion Composites center.

DO NOT make alterations or substitutions to the wheelchair structural parts or frame components without consulting Motion Composites.

2. LABELING

READ LABEL



READ

Read and follow the information in the user manual and all supplemental information provided with the wheelchair before use.

OCCUPIED TRANSIT ANCHOR KIT LABEL



WC19 OR ISO7176-19:2019

Indicates that the wheelchair is tested and approved as RESNA WC-4:2017, Section 19 or ISO 7176-19:2019 compliant wheelchair for occupied transit in a motor vehicle.



ANCHOR POINTS LABEL



ANCHOR POINTS

Indicates wheelchair anchor points to be used to secure wheelchair during occupied transit.

⚠ WARNING
A wheelchair compliant to the RESNA WC-4:2017, Section 19 or ISO 7176-19:2019 standard must have both labels as shown above. If any of these two pictograms are not on the wheelchair, it cannot be considered as compliant to the standard.

WARNING LABEL



WARNING
 Indicates a potentially hazardous condition/situation. Failure to follow designated procedures can cause either personal injury, component damage, or malfunction.

MANDATORY LABEL



MANDATORY
 These actions should be performed as specified. Failure to perform mandatory actions can cause personal injury and/or equipment damage.

PROHIBITED LABEL



PROHIBITION
 These actions are prohibited. These actions should not be performed at any time or in any circumstances. Performing a prohibited action can cause personal injury and/or equipment damage.

IMPORTANT LABEL



IMPORTANT
 Indicates important information to remember when using this product.

3. DEFINITION

ISO
 International Organization for Standardization

ANSI
 American National Standards Institute

RESNA
 Rehabilitation Engineering and Assistive Technology Society of North America

OCCUPIED TRANSIT ANCHOR KIT

A wheelchair-mounted kit that allows the wheelchair to be anchored in a motor vehicle.
 Motion Composites' occupied transit anchor kit options consist of four mounting brackets factory-installed on the wheelchair. In some markets, the kits may be offered with an optional wheelchair anchored pelvic safety belt. Always use this optional belt with the vehicle anchored chest safety belt. If this option is not present, always use the vehicle anchored three-point safety belt. NEVER rely on a positioning belt during occupied transit. Only use the designated anchor points to secure the wheelchair to the vehicle.

WHEELCHAIR TIEDOWN AND OCCUPANT RESTRAINT SYSTEMS (WTORS)

Equipments installed in a motor vehicle that allows a wheelchair and/or its occupant in the wheelchair to be anchored in the motor vehicle to restrict the movement of the occupant in case of a motor vehicle accident. The equipment consists of a system or device for securing the wheelchair and a belt-type restraint. Motion Composites occupied transit anchor kits are compatible only with four-point strap-type tiedown systems.

ANCHOR POINTS

Specific structural points on the wheelchair base or seat frame that are designed for attachment of a WTORS. These anchor points are indicated by anchor points labels.

4. PROTOCOLS AND PROCEDURES

The wheelchair user should always transfer into the vehicle seat and use the motor vehicle installed restraint system whenever feasible. The wheelchair should then be stored and secured in the vehicle. If the user deems it necessary to make a transit while occupying the wheelchair, the vehicle must be equipped with wheelchair tiedown and occupant restraint systems (WTORS) previously installed, in accordance with the manufacturer's instructions, and in compliance with RESNA WC-4:2017, Section 19 or ISO 7176-19:2019 standard. The wheelchair must be equipped with the occupied transit anchor kit, in accordance with RESNA WC-4:2017, Section 19 or ISO 7176-19:2019 standard. It is essential to use a complete WTORS four-point strap-type tiedown and occupant restraint kit to secure the wheelchair to the vehicle and provide the wheelchair occupant with a safe and an approved restraint system.

The wheelchair tiedown and occupant restraint systems (WTORS) must be used to protect the wheelchair occupant and minimize the risk of injury due to contact with the vehicle during a collision or sudden braking.

5. SECURING THE WHEELCHAIR

NOTE: In addition to following the general guidelines below, make sure you follow all recommendations and instructions provided by the WTORS manufacturer.

Always secure the wheelchair and occupant in a forward-facing position in the vehicle.

Secure the four strap-type tiedowns only at the designated anchor points. These occupied transit anchor points are indicated by anchor symbols on the wheelchair. See figure 1 and 2.

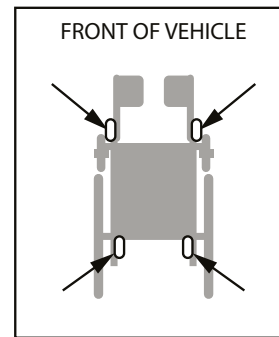
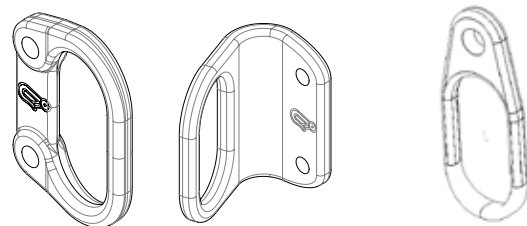

Figure 1. Anchor Points Location

Figure 2



Anchor Points

The Motion Composites occupied transit anchor kits are intended to be used with hook-type tiedown end-fittings. Tighten the four strap-type tiedowns to remove slack in each of them. Do not over-tighten. Never attach any tiedown hook to any other part of the wheelchair than the four anchor points. Attach only one tiedown strap per anchor point.

Position the vehicle tiedown mounting points for the rear tiedown straps directly in line with the rear wheelchair anchor points on the wheelchair. The front tiedown straps mounting points must be positioned wider than the wheelchair front anchor points to provide increased lateral stability. See figure 3.

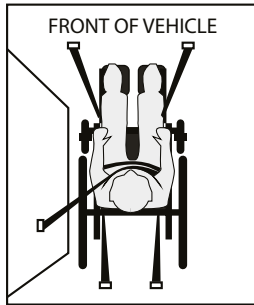

Figure 3. Securing the Wheelchair

6. SECURING THE WHEELCHAIR OCCUPANT

Once the wheelchair has been properly secured, it is essential that the wheelchair occupant be secured for transit. Both the pelvic and chest belts restraint should be adjusted as snugly as possible consistent with user comfort. Belts webbing should not be worn or twisted in a manner that reduce the area of contact of the belt webbing with the occupant when in use.

The pelvic belt should be worn low across the front of the pelvis angled between 45 and 75 degrees to the horizontal when viewed from the side. However, if the user cannot achieve this standard, an optional zone of 30 to 45 degrees can be utilized safely. Some wheelchair components, like armrests and wheels, can interfere with proper belt fit. It may be necessary to insert the belt between the armrest and the backrest or through openings between the backrest and seat in order to avoid placing the pelvic belt over the armrest. See figures 4 and 5. If a wheelchair anchored pelvic safety belt option is installed, this option is not meant to be removed from the chair. The Motion Composites wheelchair anchored pelvic belt is anchored to the rear occupied transit anchor point. Never alter the belt-restraint and/or wheelchair anchor points.

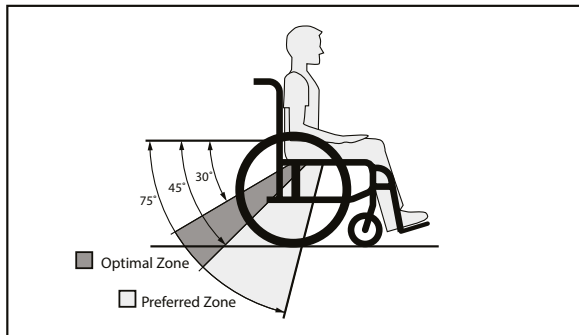

Figure 4. Recommended Pelvic Belt Placement Angles

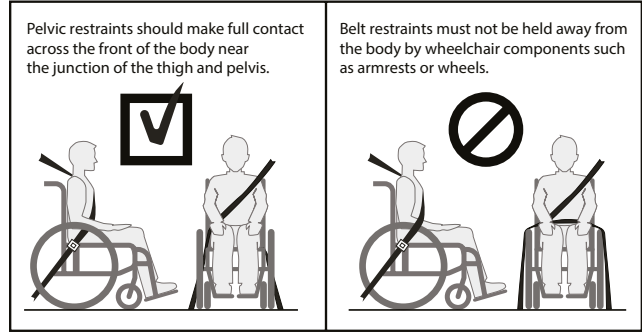

Figure 5. Proper Pelvic Belt Placement

The upper chest belt restraint should fit directly over, and in contact with, the middle of the shoulder of the occupant. See figure 6. The upper-torso belt anchor point should be anchored above and behind the top of the wheelchair occupant's shoulder to ensure that the occupant is properly restrained during transit. If a wheelchair anchored pelvic safety belt is used, place the vehicle anchored chest safety belt between the middle of the shoulder and the center of the chest, and connect to the pelvic belt near the hip of the wheelchair occupant on the opposed side of the upper vehicle anchor point and not near the midline of the occupant.

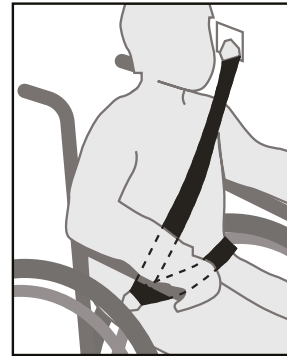

Figure 6. Upper-Torso Belt

The buckle of belt restraint systems should not be located near wheelchair components. This may come in contact with the buckle release button in case of accident or collision.

⚠ WARNING
Although postural supports and wheelchair positioning belts may be used in a moving vehicle, in addition to the vehicle's anchorage system, they should not be used to replace the vehicle's anchorage system designed and tested for this purpose, and should not interfere with the proper placement of the vehicle's seat belt.

⚠ WARNING
WARNING IF YOU FAIL TO OBSERVE THE WARNINGS IN THIS MANUAL, YOU MAY DAMAGE YOUR WHEELCHAIR, CAUSE

SEVERE PHYSICAL INJURY TO OTHERS OR SUFFER SEVERE PHYSICAL INJURIES, OR DIE

7. OCCUPIED TRANSIT SECUREMENT KIT

The occupied transit anchor kit components shall conform to ISO 7176-19:2019 or RESNA WC-4:2017, Section 19 and be installed in accordance with the manufacturer's instructions.

- Wheelchair Tiedown and Occupant Restraint System (WTORS)
- Four-point strap-type transit tiedown wheelchair system
- Wheelchair occupied transit anchor kit
- Occupant restraint safety belts

NOTE: To obtain a copy of ISO 7176-19:2019, go to: www.iso.org, ANSI/RESNA WC-4:2017, Section 19, go to webstore.ansi.org/

Rating for ease of properly positioning a belt restraint, as tested for ISO 7176-19:2019:

- HELIO C2 : Poor
- HELIO A6 : Good

Rating for the proper belt restraint positioning, as tested for ISO 7176-19:2019:

- HELIO C2, A6 : Excellent

Motion Composites have been tested and comply to RESNA WC4:2017, Section 19 in accordance with crash test requirements only.

8. WARNINGS

 **WARNING**
Kindly contact Motion Composites customer service with any questions you may have regarding the use of this wheelchair in a motor vehicle at the following number: 1 866 650-6555.

 **WARNING**
The wheelchair complies with RESNA WC-4:2017, Section 19 or ISO 7176-19:2019 and, as such, has been designed and tested for use only as a forward-facing seat in a motor vehicle.

 **WARNING**
The wheelchair has been dynamically tested in a forward-facing orientation with the ATD restrained by both pelvic and chest belts.

 **WARNING**
Both pelvic and chest safety belts should be used to reduce the possibility of head and chest impacts with the vehicle components.

 **WARNING**
This Chapter contains detailed information regarding the exact configuration of the wheelchair that was subjected to one frontal impact and other tests required by ISO 7176-19 :2019 and RESNA WC-4:2017, Section 19. See 9. *Test Configuration* of the current section. The test results apply only to the configuration of the wheelchair as tested and described in this section. Therefore, if you order your chair differently, such as with a seating system manufactured by someone other than Motion Composites, you are hereby advised that the wheelchair was not tested in such different configuration and should not be considered "transit approved" by Motion Composites. As Motion Composites has not tested the chair with such different configurations, Motion Composites has no knowledge of how the product would perform in such configuration. Therefore, Motion Composites makes no claims or warranties about the wheelchair's performance in any configuration other than the configuration described herein. Motion Composites has not authorized any person to make any such claims or warranties on its behalf.

 **WARNING**
Do not sit in this wheelchair in an adapted motor vehicle if your weight, together with the weight of all non-detachable items is more than the wheelchair permanent label maximum weight rating.

 **WARNING**
Alterations or substitutions should not be made to the wheelchair anchor points or to parts or components of the wheelchair or seating system structural members. The Motion Composites wheelchairs were tested in the configurations with the components specified in part 9. *Test Configuration* of the current section. Any significant alteration or substitution to the wheelchair's components or seating could significantly alter the chair's performance during an impact.

- ⚠ WARNING**
It is not recommended to install securement point brackets, docking securement adapters and/or pelvic belt restraint anchorages on the wheelchair after sale. Any installation or modification of an occupied transit anchor kit after sale must be made at the Motion Composites factory.
- ⚠ WARNING**
Motion Composites expressly disclaims that use of its occupied transit anchor kit option on a Motion Composites wheelchair will prevent the wheelchair user from injury or death in the event of a motor vehicle accident.
- ⚠ WARNING**
Care should be taken when applying the occupant restraint to position the seatbelt buckle so that the release button will not be contacted by wheelchair components during a crash.
- ⚠ WARNING**
Sufficient forward and rearward clear space should be provided around the wheelchair occupant in accordance with the current manual.
- ⚠ WARNING**
The wheelchair user should always transfer into the vehicle seat and use the motor vehicle installed restraint system whenever feasible. The wheelchair should then be stored and secured in the vehicle.
- ⚠ WARNING**
Do not use your Motion Composites wheelchair with a WTORS unless the WTORS has been installed fully in accordance with the instructions of the manufacturer of the WTORS.
- ⚠ WARNING**
Always attach the WTORS to your Motion Composites wheelchair at all four (4) of the Motion Composites occupied transit anchor kit option in accordance with the instructions provided by the manufacturers of the WTORS.
- ⚠ WARNING**
Always position the wheelchair occupant restraint system (pelvic belts and upper chest belts), in accordance with the instructions of the WTORS and wheelchair manufacturers. Use proper equipment. Use only as instructed.
- ⚠ WARNING**
You must use your wheelchair in accordance with all warnings and instructions in this user manual.
- ⚠ WARNING**
The back rest angle may be adjustable on your Motion Composites wheelchair. Motion Composites recommends using the same angle as the test wheelchair. Refer to section 9. TEST CONFIGURATION. Back supports should not be reclined to more than 30 degrees to the vertical during vehicle travel unless necessary for the postural and medical needs of the occupant.
- ⚠ WARNING**
The use of postural pelvic belts attached to the wheelchair base or seat frame is encouraged during travel, but these belts should be positioned so that they don't interfere with the proper positioning of crash worthy belt restraints.
- ⚠ WARNING**
Postural support accessories, such as pelvic positioning belts, anterior trunk supports and lateral trunk supports, shall not be relied on for occupant restraint in a moving vehicle unless they are labeled in compliance with RESNA WC-4:2017, Section 19 or ISO 7176-19:2019.
- ⚠ WARNING**
Whenever possible, other auxiliary wheelchair equipment should be either effectively secured to the wheelchair or removed from the wheelchair and secured in the motor vehicle during travel so that such equipment does not break free and cause injury to the vehicle occupants in case of collision.

⚠ WARNING

In order to reduce the potential injury for vehicle occupants, it is recommended that no accessories be attached to the wheelchair (trays and other accessories assembled on the wheelchair, such as IV stands, respiratory equipment, backpacks and other personal items, which are not specifically designed for safe paratransit).

To prevent they break free and cause injury to vehicle occupants in the event of a collision, other accessories must be:

1. Removed and secured separately in the vehicle.

OR

2. Secured to the wheelchair but positioned away from the occupant with energy absorbing padded cushion placed between the accessory and the occupant. The weight on the wheelchair with the occupant and the accessories must not exceed 265 lbs. In the specific case of a tray, it should also be positioned with a gap of at least 3 in (75 mm) between the edge of the tray and the wheelchair occupant's abdomen and/or chest so as not to interfere with proper belt-restraint use. However, Motion Composites does not test with such accessories. It is the user's responsibility to verify the validity of their accessory and the securing method recommended by the manufacturer of the accessory.

⚠ WARNING

If a head and neck support is required during an occupied transit, use a soft, light neck collar as they are less likely to cause neck injury in an accident. Do not secure the neck collar to the wheelchair or seating system.

⚠ WARNING

The wheelchair should be inspected by Motion Composites before reuse following involvement in any type of vehicle collision.

⚠ WARNING

Always allow for proper clear zones when securing an occupied wheelchair in a

motor vehicle. The frontal clear zone (FCZ) is measured from the forward-most point on the occupant's head and should measure at least 26 in. (66 cm) if both a pelvic and upper-torso belt are used. The frontal clear zone (FCZ) should measure at least 37.5 in. (95 cm) if only a pelvic restraint. Motion Composites strongly recommend that both pelvic and upper-torso belts be used. See figure 7.

⚠ WARNING

Allow as much clearance as possible around the wheelchair occupant to reduce the possibility of contact with vehicle components and other passengers in case of an accident.

NOTE: The recommended frontal clear zone may not be possible for seated wheelchair drivers.

The rear clear zone (RCZ) is measured from the rearmost point of the occupant's head and should be at least 20 in. (50 cm). See figure 3. The seated head height (HHT) ranges from 47 in. (120 cm) for a short adult to 61 in. (155 cm) for a tall adult. See figure 7.

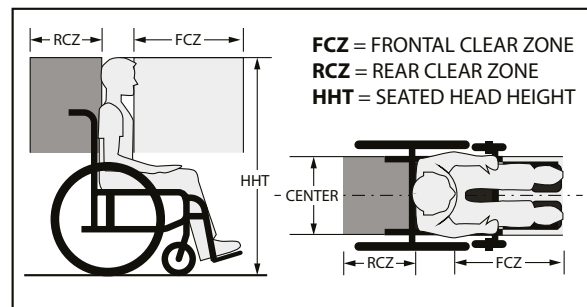

Figure 7

⚠ WARNING

All vehicle components that cannot be removed from the clear zones of Figure 3, or that near the wheelchair occupant space at a level that may be contacted by a wheelchair occupant's head during a side-impact collision or vehicle rollover, should be padded with material that complies with FMVSS 201.

⚠ WARNING

Back-support height should be set to achieve maximum engagement with the scapula (shoulder blade) and a head support should be used when possible to ensure maximum safety benefits.

⚠ WARNING
IF YOU FAIL TO OBSERVE THE WARNINGS IN THIS MANUAL, YOU MAY DAMAGE YOUR WHEELCHAIR, CAUSE SEVERE PHYSICAL INJURY TO OTHERS OR SUFFER SEVERE PHYSICAL INJURIES, OR DIE.

9. TEST CONFIGURATION

Seat Width	18 in
Seat Depth	18 in
Seat Back height.....	18 in
Front Seat-to-Floor Height	18 in
Rear Seat-to-Floor Height	16.75 in
Seat Angle.....	4 degrees
Seat Back Angle.....	10 degrees
Wheelchair Weight.....	HELIO C2 – 31 lb HELIO A6 – 35 lb, +/- 0,5 lb
Seat Upholstery.....	Adjustable tension
Backrest	Soft Nylon
Backrest canes.....	Aluminum Adjustable Height 18-21 in
Footrest Angle.....	90 degrees
Rear Wheels.....	24 in. spoke wheels with 0 degrees of camber
Rear Tire.....	Soft Urethane of 24 x 1.25 in
Caster.....	6 in with Polyurethane tire on a 3-spoke composite wheel
Angle Footplate	Fixed composite
Other options	none
Mass of ATD Dummy	172 lb
Maximum User Weight	265 lb

CONVERSION CHART

INCHES	METRIC	INCHES	METRIC	INCHES	METRIC	INCHES	METRIC
0.25 in	0.6 cm	1 in	2.5 cm	10 in	25.4 cm	19 in	48.3 cm
0.5 in	1.3 cm	2 in	5.0 cm	11 in	28.0 cm	20 in	50.8 cm
0.75 in	2.0 cm	3 in	7.6 cm	12 in	30.5 cm	21 in	53.3 cm
		4 in	10.2 cm	13 in	33.0 cm	22 in	55.9 cm
		5 in	12.7 cm	14 in	35.6 cm	23 in	58.4 cm
		6 in	15.2 cm	15 in	38.1 cm	24 in	61.0 cm
		7 in	17.8 cm	16 in	40.6 cm	25 in	63.5 cm
		8 in	20.3 cm	17 in	43.2 cm	26 in	66.0 cm
		9 in	22.9 cm	18 in	45.7 cm		

RAMQ WARRANTY CERTIFICATE

Motion Composites agrees to maintain devices, their components and parts in good working condition and to repair them, at their expenses, any defects in design or manufacturing, failure or improper operation. This warranty applies to devices, components and parts; and covers both the parts and labor required to perform the repair. The warranty also includes all administrative and transportation/shipping costs incurred in connection with its implementation.

Specifically, Motion Composites agrees to provide the following warranty periods:

(a) a minimum warranty of twelve (12) months from the date the Insured Person takes possession of the Equipment and its components, except:

- I. the chassis, for which the warranty shall be as follows:
 - i. manually propelled wheelchair (rigid frame): for life;
 - ii. manually propelled wheelchair (folding frame): 5 years;
- II. Tires, tubes, inner tubes, arm pad, armrests, back rest and back covers, and ball bearings for which the minimum warranty is thirty (30) days.

Devices and components replaced or repaired under any of these warranties shall remain under such warranty for the remainder of the warranty period.

However, components replaced or repaired under a warranty within ninety (90) days of its expiration shall be warranted for ninety (90) days, except the components replaced or repaired under the warranty provided for in subparagraph II within thirty (30) days of their expiration shall be warranted for thirty (30) days.

b) a replacement warranty at no cost, within one (1) year of the insured person taking possession of the equipment or component which has been repaired four (4) times for the same defect or not, which is out of order for a period of sixty (60) consecutive days or not.

The count begins on the first day the device or component is out of service. A repair procedure performed within one day, regardless of its duration, counts as one day. However, the supplier is not responsible for delays due to the unavailability of the insured person or Distributor to perform the repair.

A device or component is considered out of service when it is not in a condition to be used for its primary purpose.

Parts used to repair a device or component are subject to the remaining warranty of that device or component.

LIMITATION OF WARRANTIES:

The warranties do not cover any damage:

- i. due to the installation of a component or part from a third party or manufacturer not authorized by the supplier;
- ii. caused by a third party or manufacturer not authorized by the supplier;
- iii. resulting from misuse or use not in accordance with the operating and servicing instructions laid down in the user's manual.

Replacements and repairs during the warranty periods must be made with original parts and components.

Motion Composites is responsible for warranty compliance.





Motion Composites
160, Armand-Majeau Sud
Saint-Roch-de-l'Achigan, Quebec
J0K 3H0 Canada

Telephone: 1 866 650-6555
Fax: 1 888 966-6555

info@motioncomposites.com
motioncomposites.com